

PROPRIETARY NOTICE

This document discloses confidential subject matter in which MilesTek Corporation and its subsidiaries have proprietary rights. Neither receipt nor possession thereof confers or transfers any right to reproduce or disclose the document, any part thereof, any information contained therein, or any physical article or device, or to practice any method or process, except by written permission from, or written agreement with MilesTek Corporation and its subsidiaries.

REV	DESCRIPTION	DATE	APPROVED
A	REV A DRAWING RELEASED	06/22/2018	BPUCHASKI

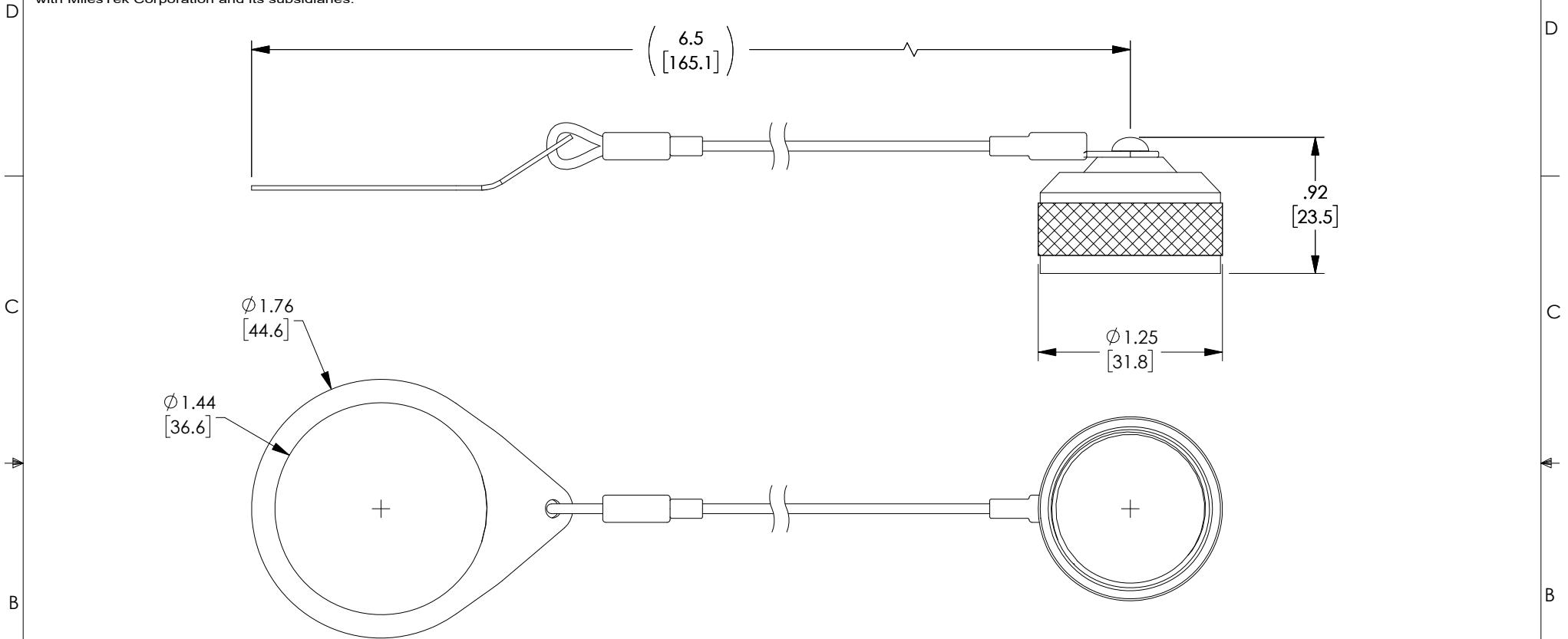

NOTES:

1. MATERIALS AND FINISH:
EXTERNAL PARTS: ALUMINUM, NICKEL TEFLON, (BLACK)
MISC. HARDWARE: STAINLESS STEEL
SEALS: SILICONE / NITRILE
LANYARD: STAINLESS STEEL (NYLON COAT)
2. USED WITH D38999 STYLE JAM NUTS.
3. ALL DIMENSIONS ARE FOR REFERENCE ONLY.
4. COMPONENT ASSEMBLY SHALL BE INDIVIDUALLY PACKAGED IN ACCORDANCE WITH MILESTEK SPECIFICATION PS-0054.

REGULATORY COMPLIANCE:
CE2011/65/EU(RoHS DIRECTIVE)

NON CONTROLLED DRAWING IF PRINTED

CAD SYSTEM DRAWING - DO NOT REVISE MANUALLY			
UNLESS OTHERWISE SPECIFIED ALL DIMENSIONS ARE IN INCHES		SIGNATURE	DATE
OVERALL CABLE LENGTH TOLERANCE: ≤12 [305] = +1 [25] / -0 >12 [305] ≤60 [1524] = +2 [51] / -0 >60 [1524] ≤120 [3048] = +4 [102] / -0 >120 [3048] ≤300 [7620] = +6 [152] / -0 >300 [7620] = +5% / -0%		DRAWN BY: BPUCHASKI	06/22/2018
ALL OTHER DIMENSIONAL TOLERANCES: .X = ±.2 [5.08] .XX = ±.02 [5.1] .XXX = ±.005 [13]		CHECKED BY: DFRISIELLO	06/22/2018
DASH NEXT ASSY USED ON APPLICATION		APPROVED ENGINEERING: D.GUITADAURO	06/22/18
CUSTOMER REFERENCE DOCUMENT:		APPROVED MANUFACTURING:	
CAGE CODE: 42977		CUSTOMER APPROVAL	
TITLE		MilesTek	
DUST CAP FOR D38999 JAM NUT NT		MILESTEK CORPORATION 301 LEORA LANE, SUITE 100 LEWISVILLE, TX 75056 PHONE: (940) 484-9400 FAX: (940) 566-1047	
DRAWING NUMBER: TMK00004		SCALE: NTS	
SHEET 1 OF 1			