

PROPRIETARY NOTICE

This document discloses confidential subject matter in which MilesTek Corporation and its subsidiaries have proprietary rights. Neither receipt nor possession thereof confers or transfers any right to reproduce or disclose the document, any part thereof, any information contained therein, or any physical article or device, or to practice any method or process, except by written permission from, or written agreement with MilesTek Corporation and its subsidiaries.

REVISIONS			
REV	DESCRIPTION	DATE	APPROVED
A	INITIAL RELEASE	06/09/17	G.HUAN

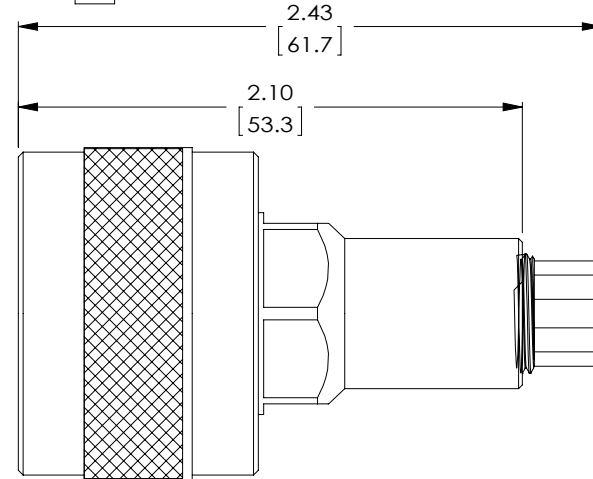
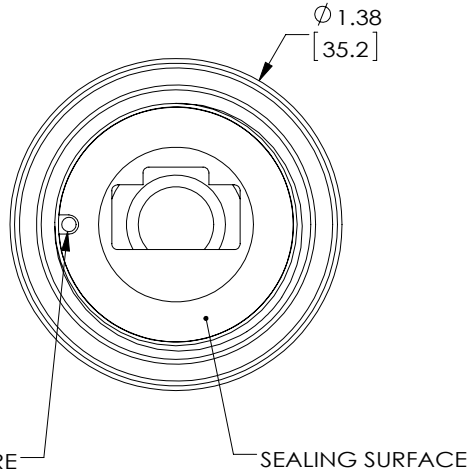
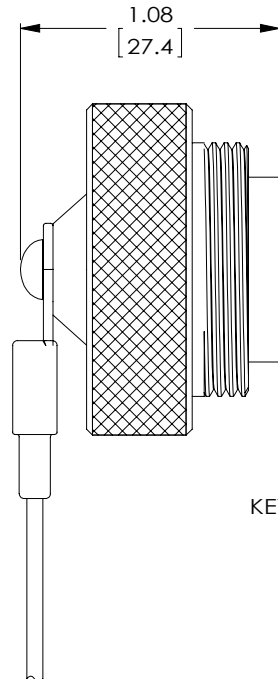

NOTES:

- CABLE SIZE: .190 / .270"
- ASSEMBLED OVERALL LENGTH IS APPROX. 2.9"
- MATERIALS AND FINISH:  
EXTERNAL PARTS: ALUMINUM/ZINC-NICKEL  
INTERNAL PARTS: ALUMINUM  
MISCELLANEOUS HARDWARE: STAINLESS STEEL  
SEAL: SILICONE  
LANYARD: STAINLESS STEEL (NYLON COAT)
- LANYARD LENGTH: APPROXIMATELY 6.0"
- RATING: IP-68
- ALL DIMENSIONS ARE FOR REFERENCE ONLY.
- COMPONENT SHALL BE INDIVIDUALLY PACKAGED IN ACCORDANCE WITH SPEC. PS-0054.
- REGULATORY COMPLIANCE:  
CE2011/65/EU(RoHS DIRECTIVE)

**NON CONTROLLED DRAWING IF PRINTED**

AS9100C CERTIFIED			CAD SYSTEM DRAWING - DO NOT REVISE MANUALLY			
UNLESS OTHERWISE SPECIFIED ALL DIMENSIONS ARE IN INCHES  OVERALL CABLE LENGTH TOLERANCES: ≤12 [305] = +1 [25] / -0 >12 [305] ≤60 [1524] = +2 [51] / -0 >60 [1524] ≤120 [3048] = +4 [102] / -0 >120 [3048] ≤300 [7620] = +6 [152] / -0 >300 [7620] = +5% / -0%  ALL OTHER DIMENSIONAL TOLERANCES: .X = ±.2 [5.08] .XX = ±.02 [0.51] .XXX = ±.003 [0.13]			SIGNATURE	DATE	MILESTEK CORPORATION 1506 INTERSTATE 35 WEST DENTON, TX 76207 PHONE: 866.524.1553 FAX: 940.591.7086	
			DRAWN BY: G.HUAN	06/09/17		
			CHECKED BY: D. GUITADAURO	06/09/17	TITLE PLUG ZNNI .190-270 DCAP	
			APPROVED ENGINEERING: S.PAN	06/09/17		
DASH NEXT ASSY USED ON			CUSTOMER APPROVAL	DRAWING NUMBER: <b>A</b> T5B00007		
APPLICATION			CUSTOMER REFERENCE DOCUMENT:	CAGE CODE: 42977	SCALE: NTS	SHEET 1 OF 1