

8 7 6 5 4 3 2 1

PROPRIETARY NOTICE

This document discloses confidential subject matter in which MilesTek Corporation and its subsidiaries have proprietary rights. Neither receipt nor possession thereof confers or transfers any right to reproduce or disclose the document, any part thereof, any information contained therein, or any physical article or device, or to practice any method or process, except by written permission from, or written agreement with MilesTek Corporation and its subsidiaries.

REV	REVISIONS		DATE	APPROVED
	DESCRIPTION			
A	INITIAL RELEASE		5/30/17	D.FRISIELLO

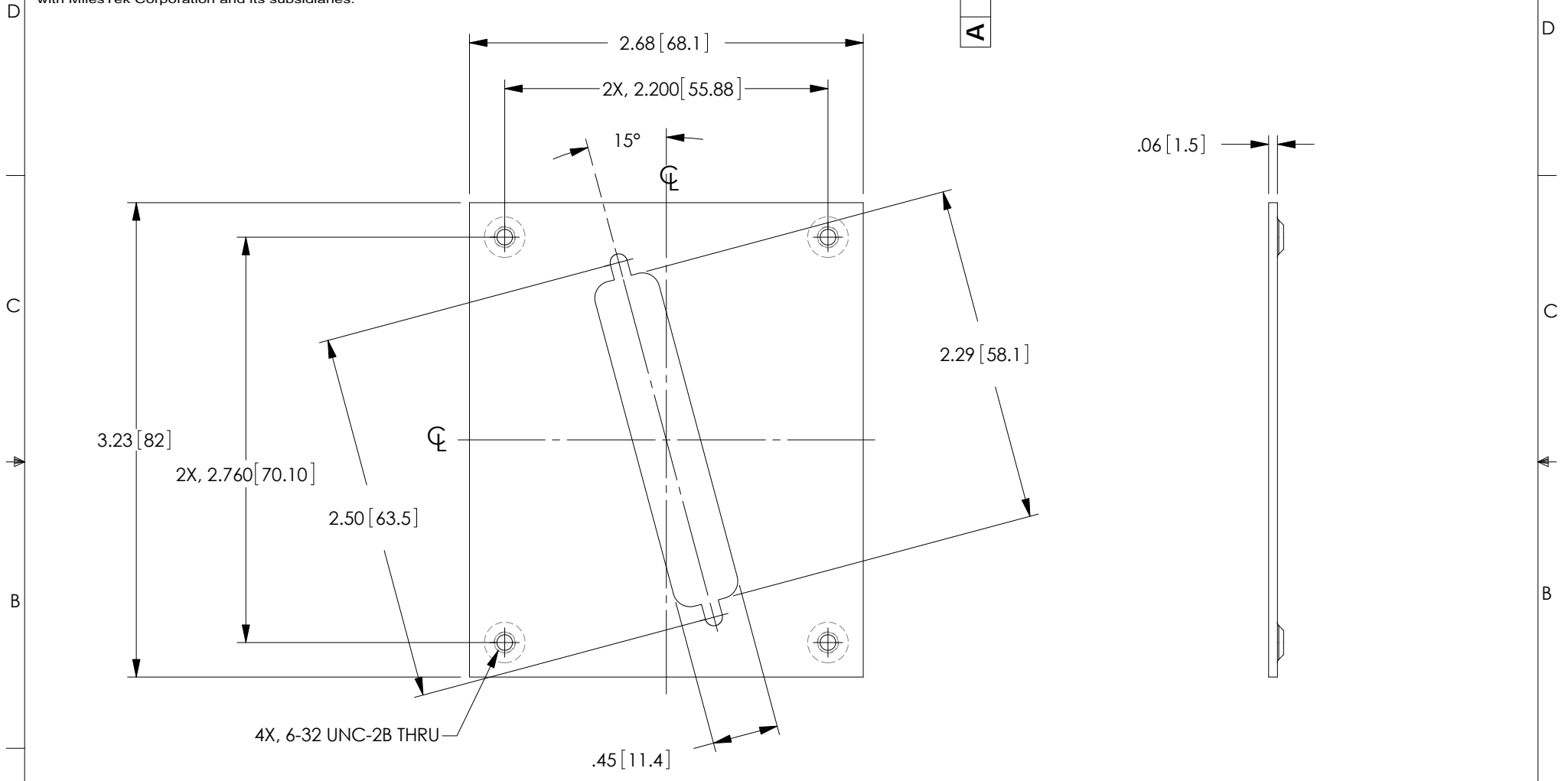

- NOTES:**
1. MATERIAL: .06 THK [1.5] COLD ROLLED STEEL.
 2. FINISH: FLAT BLACK POWDER COAT.
 3. KIT CONTAINS 4, #6-32 UNC SCREWS.
 4. ALL DIMENSIONS SHOWN ARE FOR REFERENCE ONLY.
 5. COMPONENT SHALL BE INDIVIDUALLY PACKAGED IN ACCORDANCE WITH SPECIFICATION PS-0054.

REGULATORY COMPLIANCE:
CE2011/65/EU(RoHS DIRECTIVE)

NON CONTROLLED DRAWING IF PRINTED

AS9100C CERTIFIED			CAD SYSTEM DRAWING - DO NOT REVISE MANUALLY			
UNLESS OTHERWISE SPECIFIED ALL DIMENSIONS ARE IN INCHES			SIGNATURE	DATE	MilesTek	
OVERALL CABLE LENGTH TOLERANCE: ≤12 [305] = +1 [25] / -0 >12 [305] ≤60 [1524] = +2 [51] / -0 >60 [1524] ≤120 [3048] = +4 [102] / -0 >120 [3048] ≤300 [7620] = +6 [152] / -0 >300 [7620] = +5% / -0%			DRAWN BY: D.FRISIELLO	5/30/17	MILESTEK CORPORATION 1506 INTERSTATE 35 WEST DENTON, TX 76207 PHONE: 866.524.1553 FAX: 940.591.7086	
ALL OTHER DIMENSIONAL TOLERANCES: .X = ±.2 [5.08] .XX = ±.02 [51] .XXX = ±.005 [13]			CHECKED BY: M.MARTINEZ	5/30/17	TITLE D-SUBMINATURE SUB PANEL, ANGLED DB37/HD62	
CUSTOMER REFERENCE DOCUMENT:			APPROVED ENGINEERING: M.MARTINEZ	5/30/17	DRAWING NUMBER: REF00029	
DASH	NEXT ASSY	USED ON	CUSTOMER APPROVAL	SCALE: NTS		
APPLICATION			CAGE CODE: 42977	SHEET 1 OF 1		

8 7 6 5 4 3 2 1