



TNC Plug 50 Ohm Coax Connector Crimp Attachment for RG55, RG142, RG223, RG400, RG141

RF Connectors Technical Data Sheet

MTCN0022

Configuration

- TNC Male Connector
- MIL-STD-348A
- 50 Ohms
- Straight Body Geometry
- RG55, RG142, RG223, RG400, RG141 Interface Type
- Crimp/Crimp Attachment

Applications

- General Purpose Test
- Custom Cable Assemblies

Description

MilesTek RF TNC connector will ship the same day as purchased from our broad selection of military, aerospace and industrial radio frequency components. Our TNC connector terminates to a coax interface which includes RG55, RG142, RG223, RG400 and RG141. This TNC connector for coax has a 50 Ohm impedance and is just one part of our large, in-stock inventory.

Part number MTCN0022 TNC connector from MilesTek is a male gender (also known as plug). This RF connector from MilesTek has a 6 GHz maximum frequency. Our 6 GHz TNC connector maximum frequency applies to RG55, RG142, RG223, RG400 and RG141 interfaces but may vary between them. Our radio frequency TNC male (plug) crimp/crimp connector is in-stock and does ship same-day.

Electrical Specifications

Description	Minimum	Typical	Maximum	Units
Frequency Range	DC		6	GHz
VSWR			1.5:1	
Operating Voltage (AC)			500	Vrms

Mechanical Specifications

Size	
Length	1.097 in [27.86 mm]
Width/Dia.	0.571 in [14.50 mm]
Weight	0.033 lbs [14.97 g]

Material Specifications

Description	Material	Plating
Contact	Brass	Gold 30 µin minimum
Insulation	PTFE	
Body	Brass	Nickel 100 µin minimum
Coupling Nut	Brass	Nickel 100 µin minimum

Click the following link (or enter part number in "SEARCH" on website) to obtain additional part information including price, inventory and certifications: [TNC Plug 50 Ohm Coax Connector Crimp Attachment for RG55, RG142, RG223, RG400, RG141 MTCN0022](#)



TNC Plug 50 Ohm Coax Connector Crimp Attachment for RG55, RG142, RG223, RG400, RG141

RF Connectors Technical Data Sheet

MTCN0022

Crimp Sleeve	Brass	Nickel

Environmental Specifications

Temperature

Operating Range

-65 to 165 deg C

Compliance Certifications (see [product page](#) for current document)

Plotted and Other Data

Notes:

Our offering, used primarily in military, R&D and production applications, consists of a comprehensive line of MIL-STD-1553B data bus couplers, harnesses and cable assemblies, connectors and connector termination systems. MilesTek also offers expertise in manufacturing custom cable assemblies and harnesses.

Click the following link (or enter part number in "SEARCH" on website) to obtain additional part information including price, inventory and certifications: [TNC Plug 50 Ohm Coax Connector Crimp Attachment for RG55, RG142, RG223, RG400, RG141 MTCN0022](#)

URL:

The information contained in this document is accurate to the best of our knowledge and representative of the part described herein. It may be necessary to make modifications to the part and/or the documentation of the part, in order to implement improvements. MilesTek reserves the right to make such changes as required. Unless otherwise stated, all specifications are nominal. MilesTek does not make any representation or warranty regarding the suitability of the part described herein for any particular purpose, and MilesTek does not assume any liability arising out of the use of any part or documentation.

MTCN0022 CAD Drawing

TNC Plug 50 Ohm Coax Connector Crimp Attachment
for RG55, RG142, RG223, RG400, RG141

REVISIONS			
REV.	DESCRIPTION	DATE	APPROVED
A	INITIAL RELEASE	12/03/18	SELLIS

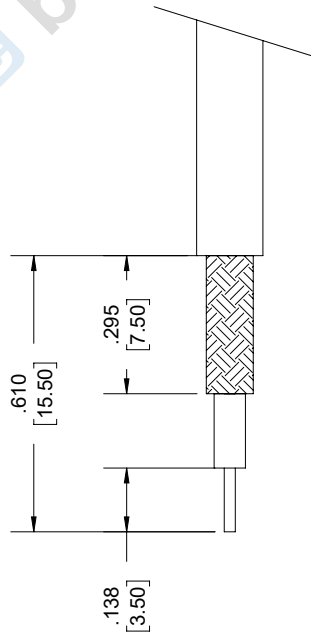
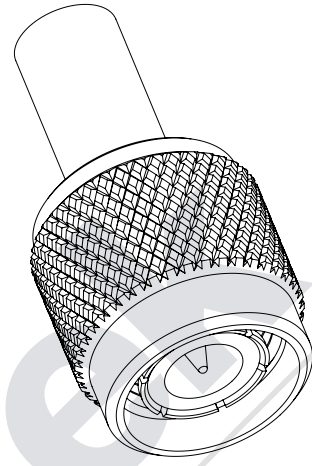
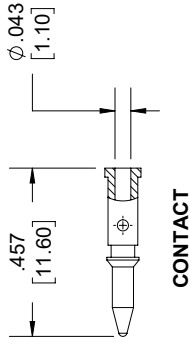
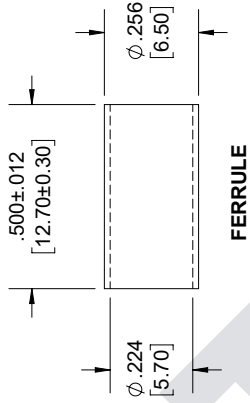
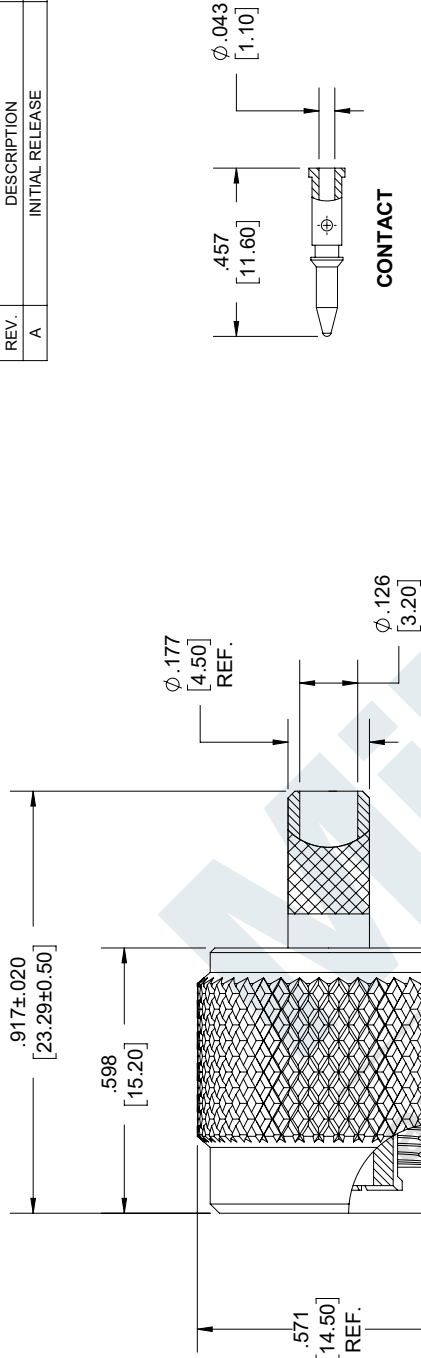

STRIPPING DIMENSIONS

NOTES:

- CABLE ATTACHMENT:
 - OUTER: CRIMP.
 - INNER: SOLDER/CRIMP.
- CRIMP SIZE REQUIRED:
 - FERRULE: .221 [5.60] HEX. CRIMP TOOL.
 - CONTACT: .071 [1.80] HEX. CRIMP TOOL.

UNLESS OTHERWISE SPECIFIED LEADING DIMENSIONS ARE IN INCHES DIMENSIONS IN [] ARE IN MILLIMETERS	
TOLERANCES:	FRACTIONS
.X±.2 [5.08]	± 1/32
.XX±.01 [.25]	± 1/64
XXX±.005 [.13]	± 1/128
ALL DIMENSIONS SHOWN ARE FOR REFERENCE ONLY.	
THRU-ANGLE PROJECTION	

		THE INFORMATION AND DESIGN IN THIS DOCUMENT IS THE PROPERTY OF MILESTEK CORPORATION. ALL RIGHTS RESERVED.	
an INFINITE brand 301 Leora Ln., Suite 100, Lewisville, TX 75056 Phone: 1.940.484.9400 1.866.524.1553 Fax: 1.972.394.7913 www.milestek.com e-mail: Customerfrms@milestek.com		SHEET	1 OF 1
SCALE	N/A		
SIZE	CAGE	DRAWN BY	PART NUMBER
A	42977	KDANG	TMCN0022
REV	A		

THESE COMMODITIES, TECHNOLOGY OR SOFTWARE WERE EXPORTED FROM THE UNITED STATES IN ACCORDANCE WITH THE EXPORT ADMINISTRATION REGULATIONS. DIVERSION CONTRARY TO U.S. LAW PROHIBITED.