

PROPRIETARY NOTICE

This document discloses confidential subject matter in which MilesTek Corporation and its subsidiaries have proprietary rights. Neither receipt nor possession thereof confers or transfers any right to reproduce or disclose the document, any part thereof, any information contained therein, or any physical article or device, or to practice any method or process, except by written permission from, or written agreement with MilesTek Corporation and its subsidiaries.

REVISIONS			
REV	DESCRIPTION	DATE	APPROVED
A	REV A DRAWING RELEASED	03/20/2019	MHEARN

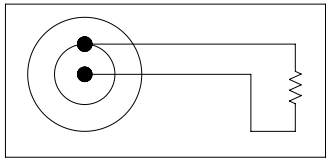
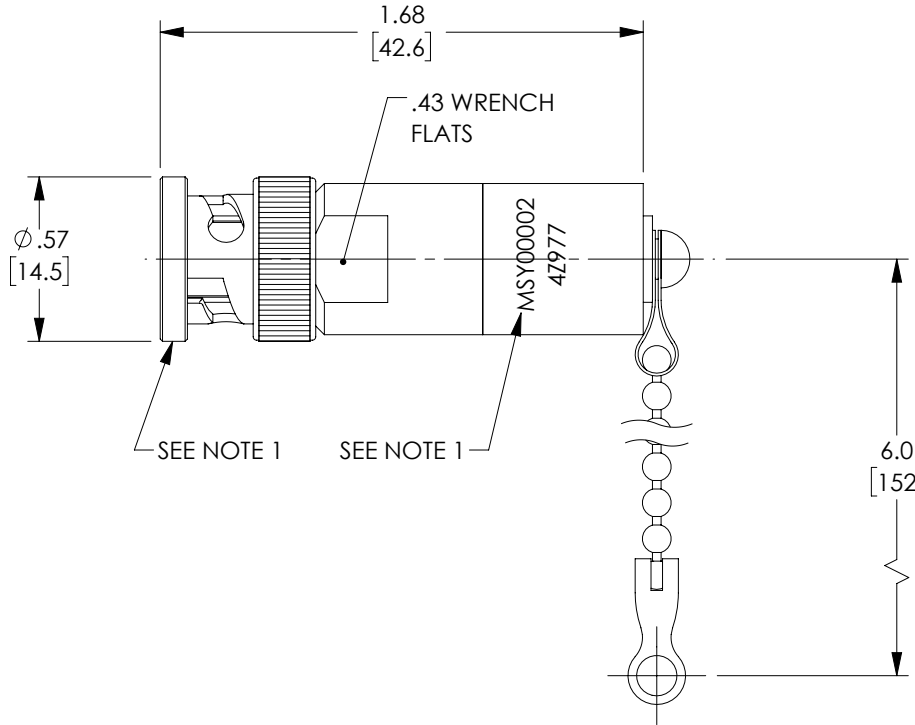
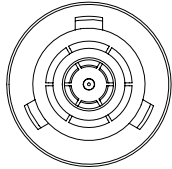

WIRE-WOUND NON-INDUCTIVE RESISTOR 1% TOLERANCE 2 WATT, AVAILABLE WITH 78.7, 1000, 2000 OR 3000 OHM VALUE

REGULATORY COMPLIANCE:

EU RoHS DIRECTIVE (MOST RECENT RELEASED VERSION)

REACH COMPLIANT

NOTES:

1. LABELING MAY EXIST IN MORE THAN ONE PLACE. MARKED AROUND THE COLLAR OR AROUND THE BODY WITH A LABEL, OR BOTH.
2. USE TERMINATORS AT EACH END OF THE BUS.
3. A STUB TERMINATOR IS NEEDED TO SIMULATE A FUTURE LOAD FROM AN UNSPECIFIED DEVICE.

<small>UNLESS OTHERWISE SPECIFIED ALL DIMENSIONS ARE IN INCHES</small> OVERALL CABLE LENGTH TOLERANCE: ≤12 [305] = +1 [25] / -0 >12 [305] ≤60 [1524] = +2 [51] / -0 >60 [1524] ≤100 [2540] = +4 [102] / -0 >100 [2540] ≤300 [7620] = +6 [152] / -0 >300 [7620] = +5% / -0% ALL OTHER DIMENSIONAL TOLERANCES: X = ± 2 [5.08] .XX = ± .02 [5.1] .XXX = ± .005 [1.3]	SIGNATURE	DATE	MILESTEK CORPORATION 301 LEORA LANE, SUITE 100 LEWISVILLE, TX 75056 PHONE: (940) 484-9400 FAX: (940) 566-1047	
	DRAWN BY: DZINN	03/20/2019		TITLE ROHS BUS TERMINATOR 78 OHM 3 SLOT 6 IN CHAIN
	CHECKED BY: DFRISIELLO	03/20/2019		
	APPROVED BY: MHEARN	03/20/2019		CONFIGURATION DETAILS OF UNDIMENSIONED FEATURES MAY VARY
CUSTOMER REFERENCE DOCUMENT:	CAGE CODE: 4Z977		SIZE A DRAWING NUMBER: MSY00002 REV. A	
SCALE: NTS		SHEET 1 OF 1		