

PROPRIETARY NOTICE
 This document discloses confidential subject matter in which MilesTek Corporation and its subsidiaries have proprietary rights. Neither receipt nor possession thereof confers or transfers any right to reproduce or disclose the document, any part thereof, any information contained therein, or any physical article or device, or to practice any method or process, except by written permission from, or written agreement with MilesTek Corporation and its subsidiaries.

LEAD FREE SOLDER

REVISIONS			
REV	DESCRIPTION	DATE	APPROVED
A	INITIAL RELEASE	05/28/2019	DFRISIELLO

WIRING MAP

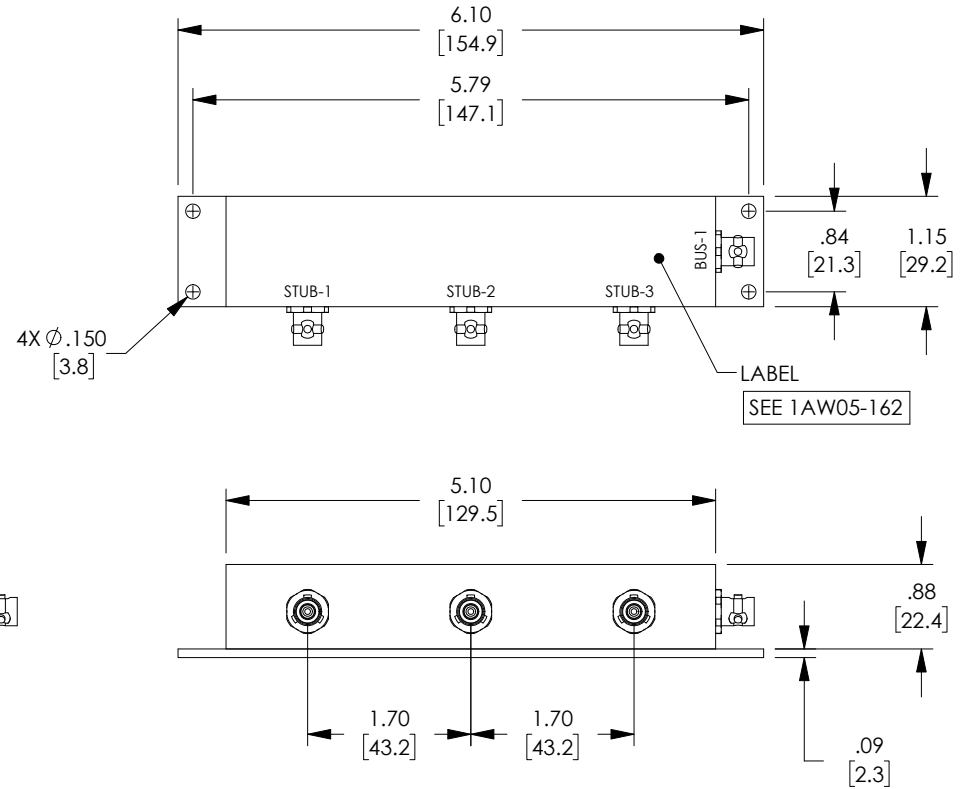
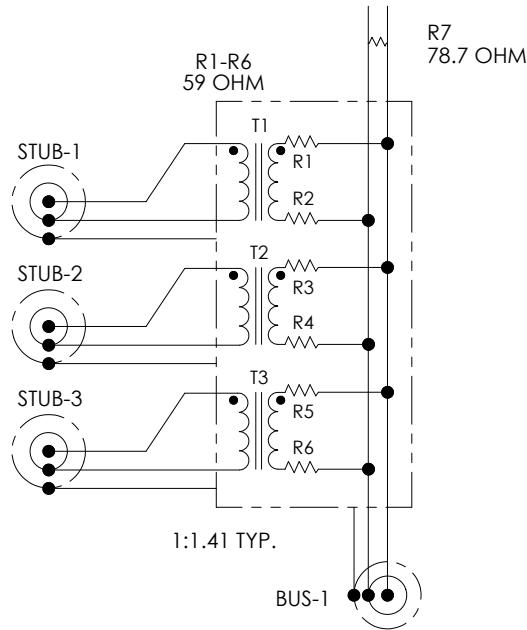

1.0 ELECTRICAL SPECIFICATIONS: IAW MIL-STD-1553B

- 1.1 DROOP 20% MAXIMUM
- 1.2 OVERSHOOT AND RINGING +/- 1.0V PK-PK
- 1.3 TRANSFORMER RATIO 1:1.41 TURNS
- 1.4 FAULT PROTECTION 59 OHM +/-1%, 2 WATT PER MIL-R-39007
- 1.5 TERMINATING RESISTOR 78.7 OHM +/-1%, 2 WATT PER MIL-R-39007
- 1.6 COMMON MODE REJECTION -55dB @ 1 MHz

2.0 MECHANICAL SPECIFICATIONS:

- 2.1 HOUSING: DIE CAST A360 ALUMINUM ALLOY
 CLEAR ANODIZED AND PAINTED WITH TEXTURE.
 BAKED ENAMEL, COLOR: BLUE
- 2.2 BASE PLATE: 6061-T6 ALUMINUM, SATIN FINISH.
- 2.3 CONNECTOR TRS PLUG OR EQUIVALENT

3.0 ENVIRONMENTAL:

- 3.1 OPERATING TEMPERATURE: -55° C TO +125° C.

4.0 ALL MATERIALS USED ARE CERTIFIED RoHS COMPLIANT.

UNLESS OTHERWISE SPECIFIED ALL DIMENSIONS ARE IN INCHES OVERALL CABLE LENGTH TOLERANCE: ≤12 [305] = +1 [25] / -0 >12 [305] ≤60 [1524] = +2 [51] / -0 >60 [1524] ≤100 [2540] = +4 [102] / -0 >100 [3048] ≤300 [7620] = +6 [152] / -0 >300 [7620] = +5% / -0% ALL OTHER DIMENSIONAL TOLERANCES: X = ± 2 [50.8] .XX = ± .02 [5.1] .XXX = ± .005 [1.3]	SIGNATURE	DATE	 MILESTEK CORPORATION 301 LEORA LANE, SUITE 100 LEWISVILLE, TX 75056 PHONE: (940) 484-9400 FAX: (940) 566-1047
	DRAWN BY: DFRISIELLO	05/22/2019	
	CHECKED BY: MHEARN	05/28/2019	
	APPROVED BY: MHEARN	05/28/2019	
CUSTOMER REFERENCE DOCUMENT:	CONFIGURATION DETAILS OF UNDIMENSIONED FEATURES MAY VARY CAGE CODE: 4Z977		TITLE ROHS 3 STUB SUBMIN TRBJ TRS BOX COUPLER
SCALE: NTS	SIZE A	DRAWING NUMBER: MSX00061	REV. A
		SHEET 1 OF 1	