

THE INFORMATION CONTAINED IN THIS DRAWING IS THE SOLE PROPERTY OF MILESTEK, INC.. ANY REPRODUCTION IN PART OR WHOLE WITHOUT THE WRITTEN PERMISSION OF MILESTEK, INC. IS PROHIBITED.

LEAD FREE SOLDER

REVISIONS			
REV	DESCRIPTION	DATE	APPROVED
A	INITIAL RELEASE	12/18/2019	MBLACKWOOD
B	ECN 10395: REVISED CABLE DESCRIPTION FROM TWCH-124-2 TO TWC-124-2	02/26/2020	MBLACKWOOD

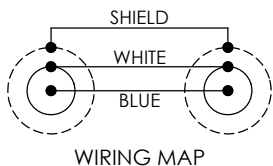
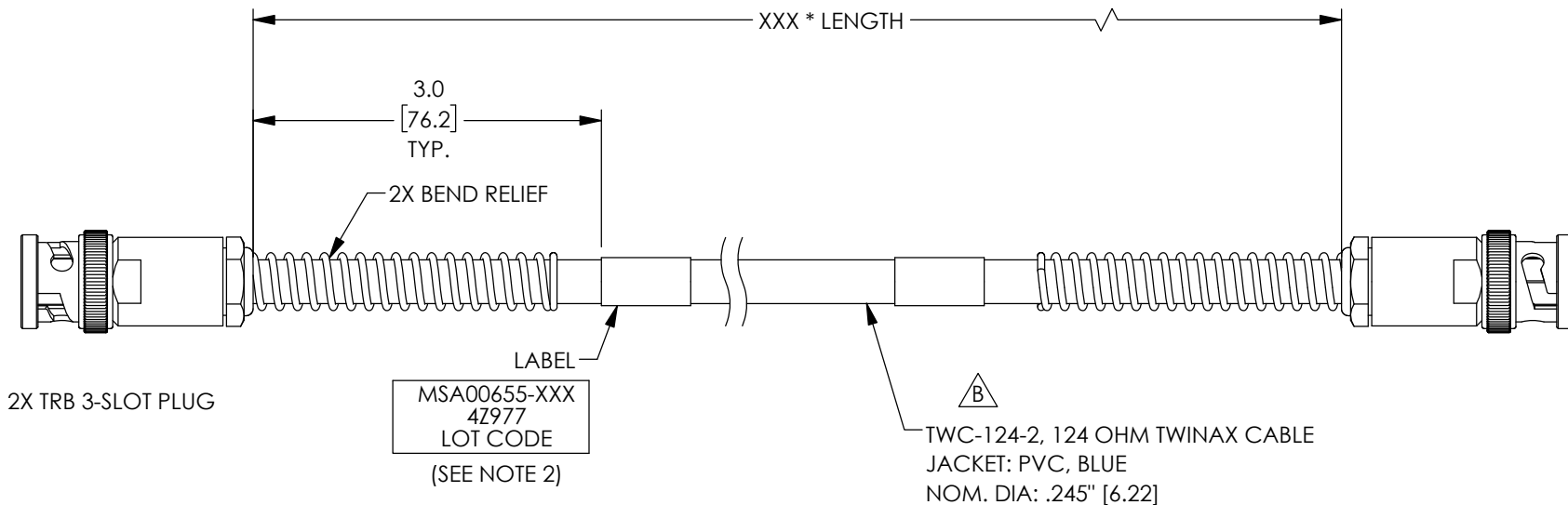

NOTES:

- *XXX = LENGTH IN INCHES
*XXXM = LENGTH IN METERS
- CABLES 48" AND UNDER HAVE 1 LABEL CENTERED. CABLES OVER 48" HAVE 2 LABELS, ONE AT EACH END 3.0" FROM THE BACK OF THE CONNECTOR.
- CABLE ASSEMBLY SHALL BE TESTED FOR CONTINUITY.

UNLESS OTHERWISE SPECIFIED, DIMENSIONS ARE IN INCHES [mm] OVERALL CABLE LENGTH TOLERANCE: ≤12 [305] = +1 [25] / -0 >12 [305] ≤60 [1524] = +2 [51] / -0 >60 [1524] ≤120 [3048] = +4 [102] / -0 >120 [3048] ≤300 [7620] = +6 [152] / -0 >300 [7620] = +5% / -0 ALL OTHER DIMENSIONAL TOLERANCES: .X = ± .2 [5] FRACTIONS ± 1/32 .XX = ± .02 [5] ANGLES ± 1° .XXX = ± .005 [1.3]	APPROVALS DRAWN BY: MVEERAPPAN CHECKED BY: DFRISIELLO APPROVED BY: MBLACKWOOD	DATE 12/18/2019 12/18/2019 12/18/2019	 an INFINIT@ brand	301 Leora Ln., Suite 100, Lewisville, TX 75056 Phone: 1.940.484.9400 1.866.524.1553
	THIRD-ANGLE PROJECTION 	CONFIGURATION DETAILS OF UNDIMENSIONED FEATURES MAY VARY COLOR VARIATIONS MAY OCCUR	CATEGORY MIL-STD-1553B	PRODUCT DESCRIPTION LEAD FREE LAB RATED 124 OHM 0.242" O.D. 1553 TWINX PBR-PBR
SIZE A		CAGE CODE 4Z977	DWG. NO. MSA00655	SCALE: NONE CAD FILE: MSA00655.SLDDRW SHEET 1 OF 1