

8 7 6 5 4 3 2 1

PROPRIETARY NOTICE
 This document discloses confidential subject matter in which MilesTek Corporation and its subsidiaries have proprietary rights. Neither receipt nor possession thereof confers or transfers any right to reproduce or disclose the document, any part thereof, any information contained therein, or any physical article or device, or to practice any method or process, except by written permission from, or written agreement with MilesTek Corporation and its subsidiaries.

| REV | REVISIONS | | |
|-----|--|----------|-------------|
| | DESCRIPTION | DATE | APPROVED |
| A | INITIAL RELEASE | 07/18/17 | G.HUAN |
| B | ECN 8899: DELETE NOTE 2, REVISE DESC., TITLE, ADD DETAIL | 9/5/17 | D.FRISIELLO |
| | | | |
| | | | |

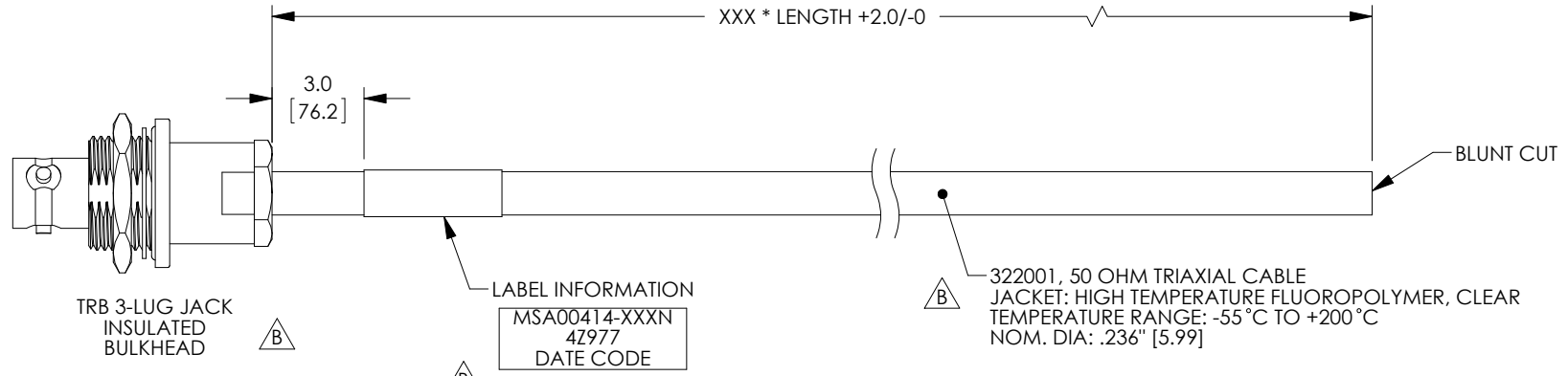

| LENGTH CODE CHART | | |
|-------------------|------------------------------|----------------------------|
| CABLE # & LENGTH | LENGTH SYMBOL | EXAMPLES OF PART # USED |
| MSA00414-XXN | WHERE XXX = LENGTH IN INCHES | MSA00414-12N (12.0 INCHES) |

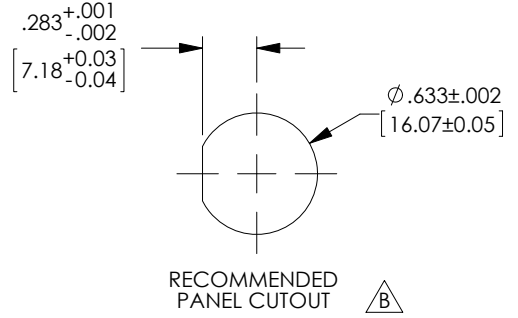
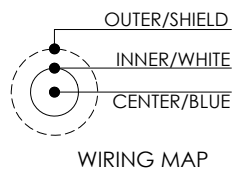

NON CONTROLLED DRAWING IF PRINTED

- NOTES:**
- *XXX = LENGTH IN INCHES
 - CABLE ASSEMBLY SHALL BE TESTED FOR CONTINUITY.

| AS9100C CERTIFIED | | | CAD SYSTEM DRAWING - DO NOT REVISE MANUALLY | | | | |
|-------------------|-----------|---------|--|----------------------------------|----------|------------------|---|
| | | | UNLESS OTHERWISE SPECIFIED ALL DIMENSIONS ARE IN INCHES | SIGNATURE | DATE | | MILESTEK CORPORATION 1506 INTERSTATE 35 WEST DENTON, TX 76207 PHONE: 866.524.1553 FAX: 940.591.7086 |
| | | | OVERALL CABLE LENGTH TOLERANCE: ≤12 [305] = +1 [25] / -0 >12 [305] ≤60 [1524] = +2 [51] / -0 >60 [1524] ≤120 [3048] = +4 [102] / -0 >120 [3048] ≤300 [7620] = +6 [152] / -0 >300 [7620] = +5% / -0% | | | | |
| | | | ALL OTHER DIMENSIONAL TOLERANCES: .X = ±.2 [5.08] .XX = ±.02 [5.1] .XXX = ±.005 [13] | DRAWN BY: G.HUAN | 07/18/17 | SIZE A | DRAWING NUMBER: MSA00414-XXXN |
| | | | | CHECKED BY: M.HEARN | 07/19/17 | | |
| | | | | APPROVED ENGINEERING: M.HEARN | 07/19/17 | | |
| | | | | APPROVED MANUFACTURING: | | | |
| | | | | CUSTOMER APPROVAL | | | |
| DASH | NEXT ASSY | USED ON | CUSTOMER REFERENCE DOCUMENT: | CAGE CODE: 4Z977 | | | |
| APPLICATION | | | | | | | |

8 7 6 5 4 3 2 1