

PROPRIETARY NOTICE

This document discloses confidential subject matter in which MilesTek Corporation and its subsidiaries have proprietary rights. Neither receipt nor possession thereof confers or transfers any right to reproduce or disclose the document, any part thereof, any information contained therein, or any physical article or device, or to practice any method or process, except by written permission from, or written agreement with MilesTek Corporation and its subsidiaries.

REV	DESCRIPTION	DATE	APPROVED
A	INITIAL RELEASE	06/27/17	G.HUAN
B	ECN 8899: REVISE NOTE 1 TO NOTE 2, DESCR, TITLE, ADD DETAIL	8/31/17	D.FRISIELLO

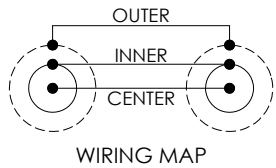
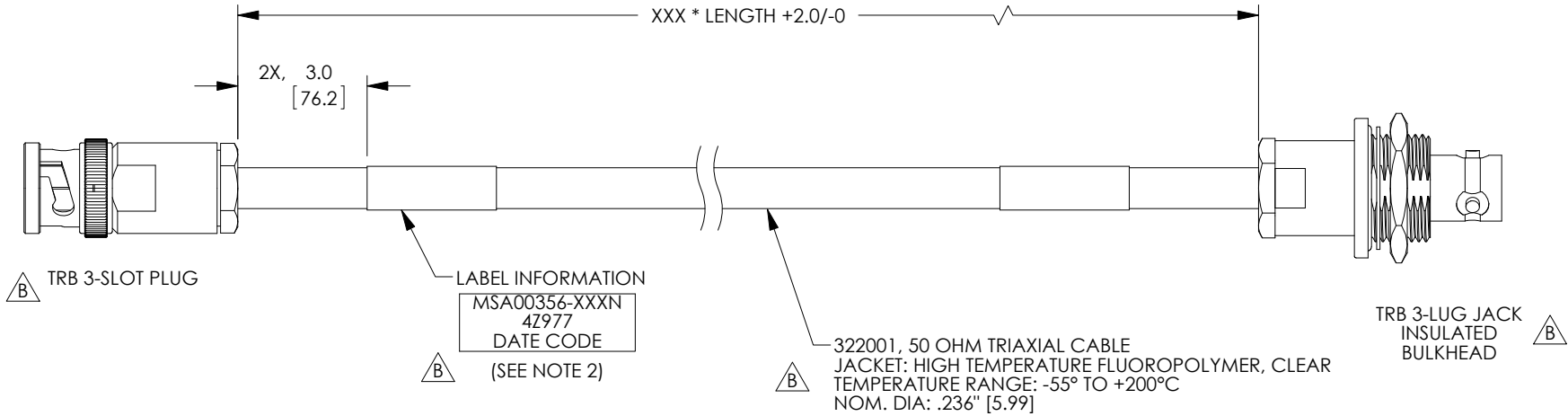

LENGTH CODE CHART		
CABLE # & LENGTH	LENGTH SYMBOL	EXAMPLES OF PART # USED
MSA00356-XXN	WHERE XXX = LENGTH IN INCHES	MSA00356-12N (12.0 INCHES)

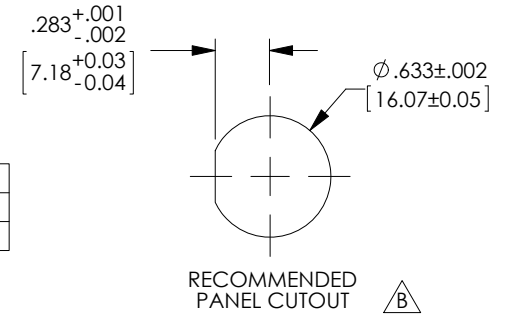

NON CONTROLLED DRAWING IF PRINTED

NOTES:

- *XXX = LENGTH IN INCHES
- CABLES 48" AND UNDER HAVE 1 LABEL CENTERED. CABLES OVER 48" HAVE 2 LABELS, ONE AT EACH END 3.0" FROM THE BACK OF THE CONNECTOR.
- CABLE ASSEMBLY SHALL BE TESTED FOR CONTINUITY.

AS9100C CERTIFIED			CAD SYSTEM DRAWING - DO NOT REVISE MANUALLY			
DRAWN BY:	G.HUAN	DATE:	06/27/17		MILESTEK CORPORATION 1506 INTERSTATE 35 WEST DENTON, TX 76207 PHONE: 866.524.1553 FAX: 940.591.7086	
CHECKED BY:	M.HEARN	DATE:	06/28/17		TITLE: CA HT TRIAX P-IN BHJ	
APPROVED ENGINEERING:	M.HEARN	DATE:	06/28/17	DRAWING NUMBER: MSA00356-XXXX		
APPROVED MANUFACTURING:		CUSTOMER APPROVAL:		SCALE: NTS		
DASH	NEXT ASSY	USED ON	APPLICATION		CAGE CODE: 4Z977	
CUSTOMER REFERENCE DOCUMENT:			SHEET 1 OF 1			