

8

7

6

5

4

3

2

1

PROPRIETARY NOTICE

This document discloses confidential subject matter in which MilesTek Corporation and its subsidiaries have proprietary rights. Neither receipt nor possession thereof confers or transfers any right to reproduce or disclose the document, any part thereof, any information contained therein, or any physical article or device, or to practice any method or process, except by written permission from, or written agreement with MilesTek Corporation and its subsidiaries.

MSA00303-XXXN
A

| REVISIONS | | | |
|-----------|-------------------------------------------------------------|----------|-------------|
| REV | DESCRIPTION | DATE | APPROVED |
| A | INITIAL RELEASE | 06/27/17 | G.HUAN |
| B | ECN 8899: REVISE NOTE 1 TO NOTE 2, DESCR, TITLE, ADD DETAIL | 8/30/17 | D.FRISIELLO |
| | | | |
| | | | |

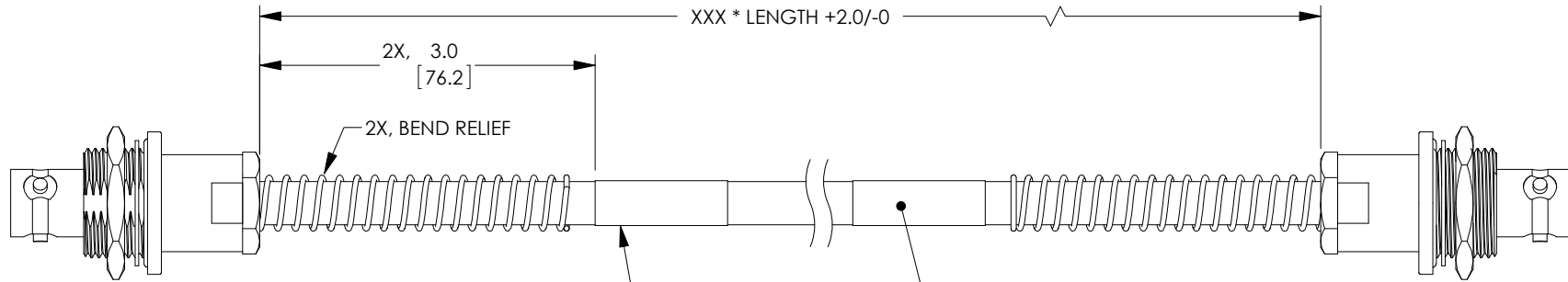

2X, TRB 3-LUG JACK INSULATED BULKHEAD WITH BEND RELIEF

LABEL INFORMATION

| |
|---------------|
| MSA00303-XXXN |
| 4Z977 |
| DATE CODE |

(SEE NOTE 2)

50 OHM TRIAXIAL CABLE
 JACKET: HALOGEN FREE POLYOLEFIN, YELLOW
 NOM. DIA: .245" [6.15]
 OPER. TEMP: -30°C TO +80°C

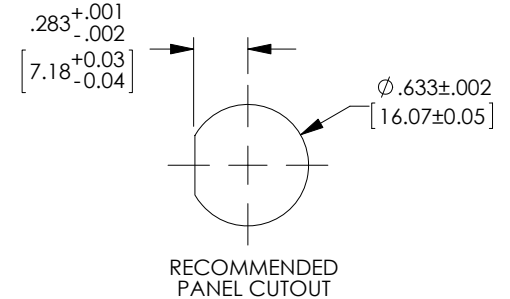
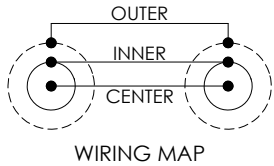

| LENGTH CODE CHART | | |
|-------------------|------------------------------|----------------------------|
| CABLE # & LENGTH | LENGTH SYMBOL | EXAMPLES OF PART # USED |
| MSA00303-XXN | WHERE XXX = LENGTH IN INCHES | MSA00303-12N (12.0 INCHES) |

NON CONTROLLED DRAWING IF PRINTED

NOTES:

- *XXX = LENGTH IN INCHES
- CABLES 48" AND UNDER HAVE 1 LABEL CENTERED. CABLES OVER 48" HAVE 2 LABELS, ONE AT EACH END 3.0" FROM THE BACK OF THE CONNECTOR.
- CABLE ASSEMBLY SHALL BE TESTED FOR CONTINUITY.

| AS9100C CERTIFIED | | | CAD SYSTEM DRAWING - DO NOT REVISE MANUALLY | | | | |
|-------------------|-----------|---------|--------------------------------------------------------------------------------------------------------------------------------------------------------------------------------------------------------------------------------------------------------|----------------------------------|----------|-------------------------|-----------------------------------------------------------------------------------------------------------------|
| | | | UNLESS OTHERWISE SPECIFIED ALL DIMENSIONS ARE IN INCHES | SIGNATURE | DATE | | MILESTEK CORPORATION 1506 INTERSTATE 35 WEST DENTON, TX 76207 PHONE: 866.524.1553 FAX: 940.591.7086 |
| | | | OVERALL CABLE LENGTH TOLERANCE: ≤ 12 [305] = +1 [25] / -0 > 12 [305] ≤ 60 [1524] = +2 [51] / -0 > 60 [1524] ≤ 120 [3048] = +4 [102] / -0 > 120 [3048] ≤ 300 [7620] = +6 [152] / -0 > 300 [7620] = +5% / -0% | | | | |
| | | | ALL OTHER DIMENSIONAL TOLERANCES: $X = \pm .2$ [5.08] $.XX = \pm .02$ [5.1] $.XXX = \pm .005$ [1.3] | CHECKED BY: G.HUAN | 06/27/17 | TITLE | |
| | | | CUSTOMER REFERENCE DOCUMENT: | APPROVED ENGINEERING: M.HEARN | 06/28/17 | CA HF TRIAX IN BHBR J-J | |
| | | | | APPROVED MANUFACTURING: | | DRAWING NUMBER: | |
| DASH | NEXT ASSY | USED ON | | CUSTOMER APPROVAL | | MSA00303-XXXN | |
| | | | | | | SCALE: NTS | SHEET 1 OF 1 |
| | | | APPLICATION | CAGE CODE: 4Z977 | | | |

8

7

6

5

4

3

2

1