

PROPRIETARY NOTICE
 This document discloses confidential subject matter in which MilesTek Corporation and its subsidiaries have proprietary rights. Neither receipt nor possession thereof confers or transfers any right to reproduce or disclose the document, any part thereof, any information contained therein, or any physical article or device, or to practice any method or process, except by written permission from, or written agreement with MilesTek Corporation and its subsidiaries.

REVISIONS			
REV	DESCRIPTION	DATE	APPROVED
A	INITIAL RELEASE	06/27/17	G.HUAN
B	ECN 8899: REVISE NOTE 1 TO NOTE 2, DESCR, TITLE, ADD DETAIL	8/30/17	D.FRISIELLO

MSA00292-XXXX
A

D
C
B
A

D
C
B
A

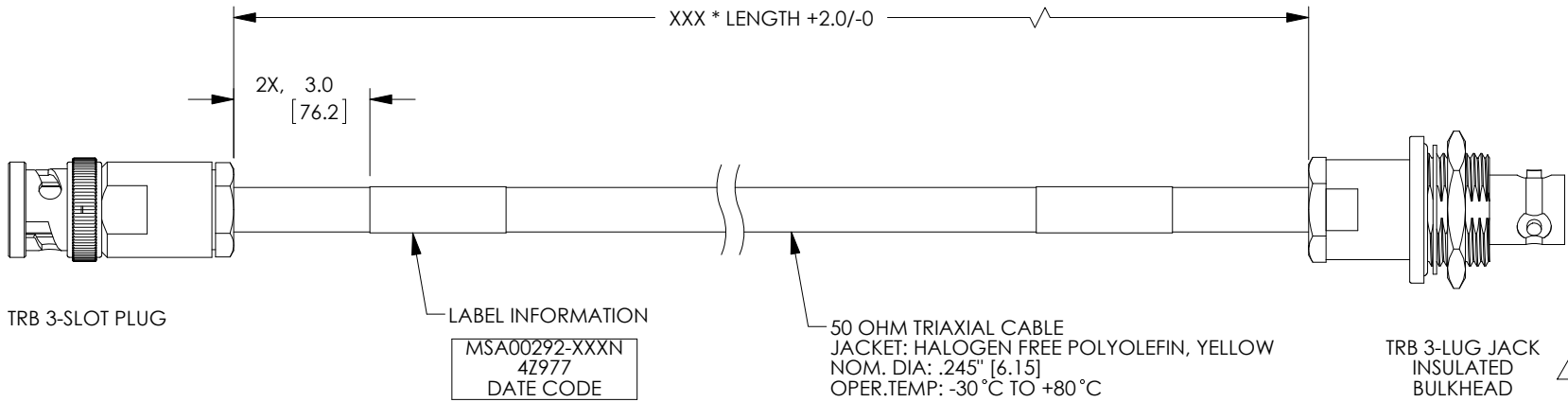

B TRB 3-SLOT PLUG

LABEL INFORMATION

MSA00292-XXXX
4Z977
DATE CODE

B (SEE NOTE 2)

50 OHM TRIAXIAL CABLE
 JACKET: HALOGEN FREE POLYOLEFIN, YELLOW
 NOM. DIA: .245" [6.15]
 OPER. TEMP: -30°C TO +80°C

TRB 3-LUG JACK
 INSULATED
 BULKHEAD

B

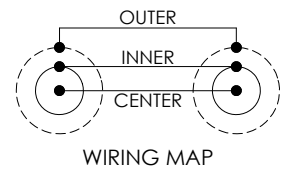

WIRING MAP

LENGTH CODE CHART		
CABLE # & LENGTH	LENGTH SYMBOL	EXAMPLES OF PART # USED
MSA00292-XXN	WHERE XXX = LENGTH IN INCHES	MSA-00292-12N (12.0 INCHES)

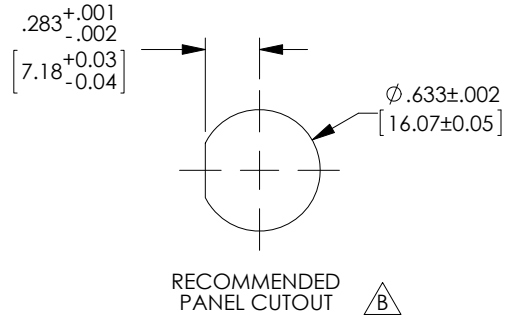

RECOMMENDED
 PANEL CUTOUT **B**

NON CONTROLLED DRAWING IF PRINTED **B**

- NOTES:**
- *XXX = LENGTH IN INCHES
 - CABLES 48" AND UNDER HAVE 1 LABEL CENTERED. CABLES OVER 48" HAVE 2 LABELS, ONE AT EACH END 3.0" FROM THE BACK OF THE CONNECTOR.
 - CABLE ASSEMBLY SHALL BE TESTED FOR CONTINUITY.

AS9100C CERTIFIED			CAD SYSTEM DRAWING - DO NOT REVISE MANUALLY				
DASH	NEXT ASSY	USED ON	UNLESS OTHERWISE SPECIFIED ALL DIMENSIONS ARE IN INCHES	SIGNATURE	DATE		MILESTEK CORPORATION 1506 INTERSTATE 35 WEST DENTON, TX 76207 PHONE: 866.524.1553 FAX: 940.591.7086
			OVERALL CABLE LENGTH TOLERANCE: ≤12 [305] = +1 [25] / -0 >12 [305] ≤60 [1524] = +2 [51] / -0 >60 [1524] ≤120 [3048] = +4 [102] / -0 >120 [3048] ≤300 [7620] = +6 [152] / -0 >300 [7620] = +5% / -0%	G.HUAN	06/27/17		
			ALL OTHER DIMENSIONAL TOLERANCES: .X = ±.2 [5.08] .XX = ±.02 [5.1] .XXX = ±.005 [1.3]	M.HEARN	06/28/17	TITLE	CA HF TRIAX P-IN BHJ
			CUSTOMER REFERENCE DOCUMENT:	M.HEARN	06/28/17	SIZE	A
			APPLICATION	CUSTOMER APPROVAL		DRAWING NUMBER:	MSA00292-XXXX
						SCALE: NTS	SHEET 1 OF 1
				CAGE CODE: 4Z977			