

PROPRIETARY NOTICE

This document discloses confidential subject matter in which MilesTek Corporation and its subsidiaries have proprietary rights. Neither receipt nor possession thereof confers or transfers any right to reproduce or disclose the document, any part thereof, any information contained therein, or any physical article or device, or to practice any method or process, except by written permission from, or written agreement with MilesTek Corporation and its subsidiaries.

| REV | REVISIONS  |          |             |
|-----|--|----------|-------------|
|     | DESCRIPTION  | DATE     | APPROVED    |
| A   | INITIAL RELEASE  | 06/30/17 | J.YOU       |
| B   | ECN 8899: REVISE NOTE 1 TO NOTE 2, DESCR., TITLE, ADD DETAIL | 9/11/17  | D.FRISIELLO |
|     |  |          |             |
|     |  |          |             |

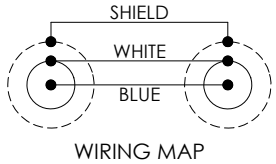
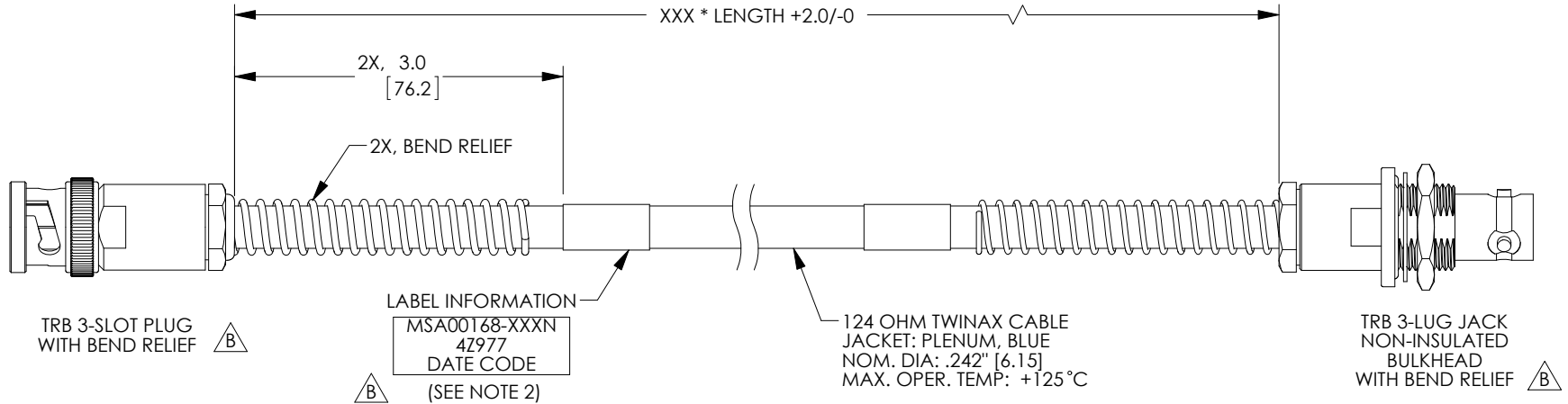

| LENGTH CODE CHART |                              |                            |
|-------------------|------------------------------|----------------------------|
| CABLE # & LENGTH  | LENGTH SYMBOL                | EXAMPLES OF PART # USED    |
| MSA00168-XXXN     | WHERE XXX = LENGTH IN INCHES | MSA00168-12N (12.0 INCHES) |

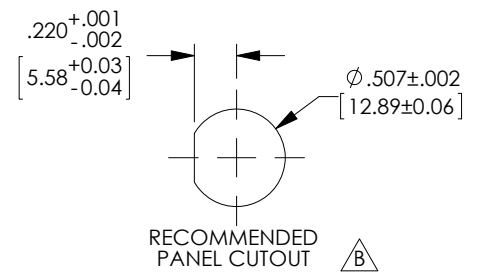

- NOTES:**
- \*XXX = LENGTH IN INCHES
  - CABLES 48" AND UNDER HAVE 1 LABEL CENTERED. CABLES OVER 48" HAVE 2 LABELS, ONE AT EACH END 3.0" FROM THE BACK OF THE CONNECTOR.
  - CABLE ASSEMBLY SHALL BE TESTED FOR CONTINUITY.

**NON CONTROLLED DRAWING IF PRINTED**

|  |  |   |                   |   |  |
|--|--|---|-------------------|---|--|
| AS9100C CERTIFIED  |  | CAD SYSTEM DRAWING - DO NOT REVISE MANUALLY |                   |   |  |
| UNLESS OTHERWISE SPECIFIED ALL DIMENSIONS ARE IN INCHES  |  | SIGNATURE                                   | DATE              | <br>MILESTEK CORPORATION<br>1506 INTERSTATE 35 WEST<br>DENTON, TX 76207<br>PHONE: 866.524.1553<br>FAX: 940.591.7086 |  |
| OVERALL CABLE LENGTH TOLERANCE:<br>≤12 [305] = +1 [25] / -0<br>>12 [305] ≤60 [1524] = +2 [51] / -0<br>>60 [1524] ≤120 [3048] = +4 [102] / -0<br>>120 [3048] ≤300 [7620] = +6 [152] / -0<br>>300 [7620] = +5% / -0% |  | DRAWN BY:<br>J.YOU                          | 06/30/17          |   |  |
| ALL OTHER DIMENSIONAL TOLERANCES:<br>.X = ±.2 [5.08]<br>.XX = ±.02 [1.51]<br>.XXX = ±.005 [1.3]  |  | CHECKED BY:<br>M.HEARN                      | 06/30/17          | TITLE<br>PLN TWN PBR-NI BHJBR   |  |
| DASH NEXT ASSY USED ON   |  | APPROVED ENGINEERING:<br>M.HEARN            | 06/30/17          |   |  |
| APPLICATION  |  | APPROVED MANUFACTURING:                     | CUSTOMER APPROVAL | DRAWING NUMBER:<br>MSA00168-XXXN  |  |
| CUSTOMER REFERENCE DOCUMENT:   |  | CAGE CODE: 42977                            |                   | SCALE: NTS SHEET 1 OF 1   |  |