

8 7 6 5 4 3 2 1

PROPRIETARY NOTICE

This document discloses confidential subject matter in which MilesTek Corporation and its subsidiaries have proprietary rights. Neither receipt nor possession thereof confers or transfers any right to reproduce or disclose the document, any part thereof, any information contained therein, or any physical article or device, or to practice any method or process, except by written permission from, or written agreement with MilesTek Corporation and its subsidiaries.

REV	REVISIONS		
	DESCRIPTION	DATE	APPROVED
A	INITIAL RELEASE	06/30/17	J.YOU
B	ECN 8899: DELETE NOTE 2, REVISE DESCRIPTIONS, TITLE	9/8/17	D.FRISIELLO

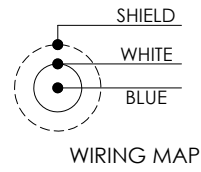
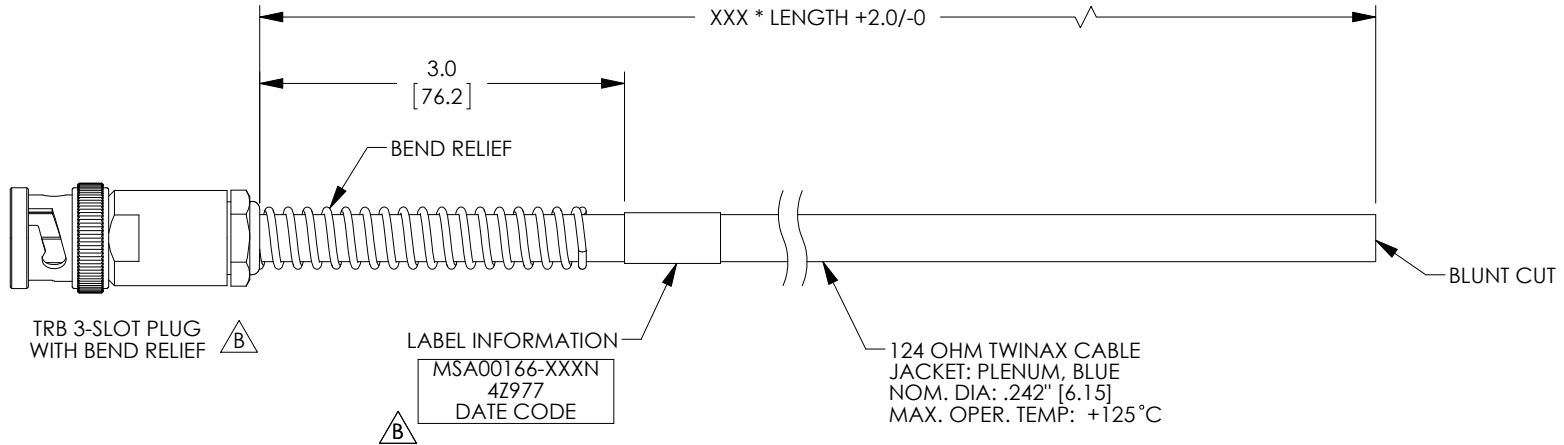

LENGTH CODE CHART		
CABLE # & LENGTH	LENGTH SYMBOL	EXAMPLES OF PART # USED
MSA00166-XXXX	WHERE XXX = LENGTH IN INCHES	MSA00166-12N (12.0 INCHES)

NON CONTROLLED DRAWING IF PRINTED



- NOTES:**
- *XXX = LENGTH IN INCHES
 - CABLE ASSEMBLY SHALL BE TESTED FOR CONTINUITY.

AS9100C CERTIFIED			CAD SYSTEM DRAWING - DO NOT REVISE MANUALLY				
			UNLESS OTHERWISE SPECIFIED ALL DIMENSIONS ARE IN INCHES	SIGNATURE	DATE		MILESTEK CORPORATION 1506 INTERSTATE 35 WEST DENTON, TX 76207 PHONE: 866.524.1553 FAX: 940.591.7086
			OVERALL CABLE LENGTH TOLERANCE: ≤12 [305] = +1 [25] / -0 >12 [305] ≤60 [1524] = +2 [51] / -0 >60 [1524] ≤120 [3048] = +4 [102] / -0 >120 [3048] ≤300 [7620] = +6 [152] / -0 >300 [7620] = +5% / -0%	DRAWN BY: J.YOU 06/30/17	CHECKED BY: M.HEARN 06/30/17		
			ALL OTHER DIMENSIONAL TOLERANCES: .X = ±.2 [5.08] .XX = ±.02 [5.1] .XXX = ±.005 [1.3]	APPROVED MANUFACTURING: M.HEARN 06/30/17	CUSTOMER APPROVAL	SIZE A	DRAWING NUMBER: MSA00166-XXXX
DASH	NEXT ASSY	USED ON	CUSTOMER REFERENCE DOCUMENT:	CAGE CODE: 4Z977		SCALE: NTS	SHEET 1 OF 1
APPLICATION							

8 7 6 5 4 3 2 1