

8

7

6

5

4

3

2

1

PROPRIETARY NOTICE

This document discloses confidential subject matter in which MilesTek Corporation and its subsidiaries have proprietary rights. Neither receipt nor possession thereof confers or transfers any right to reproduce or disclose the document, any part thereof, any information contained therein, or any physical article or device, or to practice any method or process, except by written permission from, or written agreement with MilesTek Corporation and its subsidiaries.

MSA00164-XXXX
A

REVISIONS			
REV	DESCRIPTION	DATE	APPROVED
A	INITIAL RELEASE	06/30/17	J.YOU
B	ECN 8899: REVISE NOTE 1 TO NOTE 2, DESCR., TITLE, ADD DETAIL	9/8/17	D.FRISIELLO

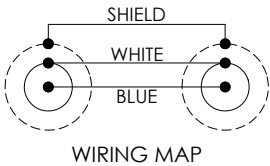
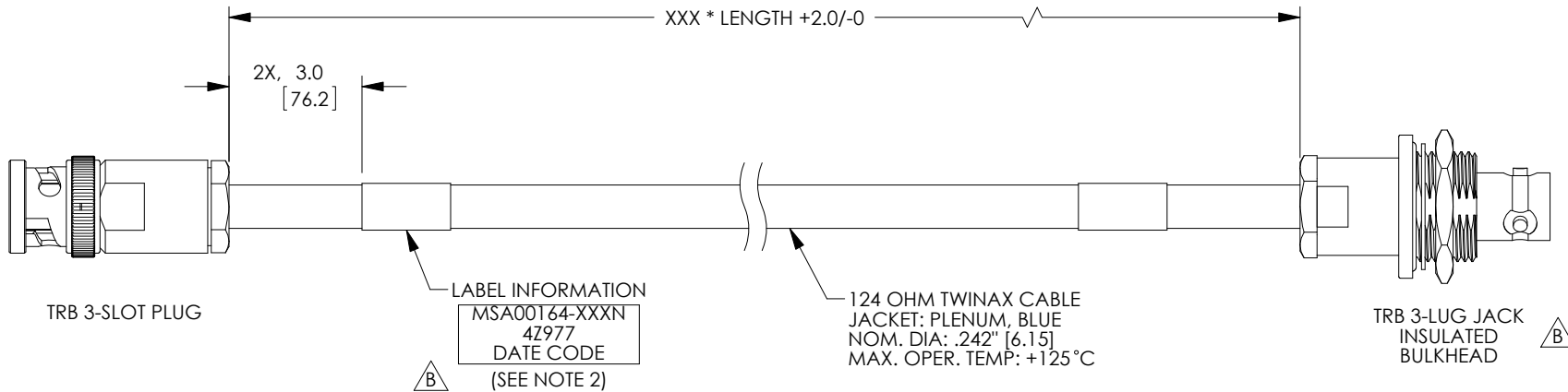

LENGTH CODE CHART		
CABLE # & LENGTH	LENGTH SYMBOL	EXAMPLES OF PART # USED
MSA00164-XXXX	WHERE XXX = LENGTH IN INCHES	MSA00164-12N (12.0 INCHES)

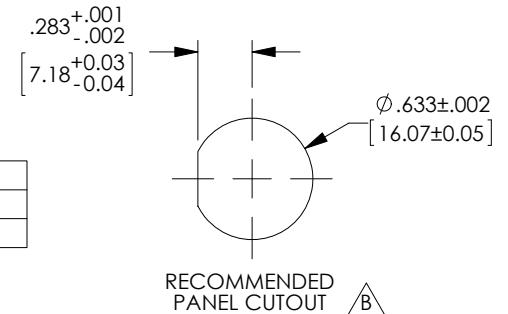

NOTES:

- *XXX = LENGTH IN INCHES
- CABLES 48" AND UNDER HAVE 1 LABEL CENTERED. CABLES OVER 48" HAVE 2 LABELS, ONE AT EACH END 3.0" FROM THE BACK OF THE CONNECTOR.
- CABLE ASSEMBLY SHALL BE TESTED FOR CONTINUITY.

NON CONTROLLED DRAWING IF PRINTED

AS9100C CERTIFIED			CAD SYSTEM DRAWING - DO NOT REVISE MANUALLY			
UNLESS OTHERWISE SPECIFIED ALL DIMENSIONS ARE IN INCHES			SIGNATURE	DATE	MilesTek	MILESTEK CORPORATION 1506 INTERSTATE 35 WEST DENTON, TX 76207 PHONE: 866.524.1553 FAX: 940.591.7086
OVERALL CABLE LENGTH TOLERANCE: ≤12 [305] = +1 [25] / -0 >12 [305] ≤60 [1524] = +2 [51] / -0 >60 [1524] ≤120 [3048] = +4 [102] / -0 >120 [3048] ≤300 [7620] = +6 [152] / -0 >300 [7620] = +5% / -0%			DRAWN BY: J.YOU	06/30/17		
ALL OTHER DIMENSIONAL TOLERANCES: .X = ±.2 [5.08] .XX = ±.02 [5.1] .XXX = ±.005 [1.3]			CHECKED BY: M.HEARN	06/30/17	DRAWING NUMBER: MSA00164-XXXX	
CUSTOMER REFERENCE DOCUMENT:			APPROVED ENGINEERING: M.HEARN	06/30/17		SCALE: NTS
DASH	NEXT ASSY	USED ON	APPROVED MANUFACTURING:	CUSTOMER APPROVAL	CAGE CODE: 4Z977	
APPLICATION						

8

7

6

5

4

3

2

1