

PROPRIETARY NOTICE

This document discloses confidential subject matter in which MilesTek Corporation and its subsidiaries have proprietary rights. Neither receipt nor possession thereof confers or transfers any right to reproduce or disclose the document, any part thereof, any information contained therein, or any physical article or device, or to practice any method or process, except by written permission from, or written agreement with MilesTek Corporation and its subsidiaries.

REVISIONS			
REV	DESCRIPTION	DATE	APPROVED
A	INITIAL RELEASE	06/30/17	J.YOU
B	ECN 8899: DELETE NOTE 2, REVISE DESCRIPTIONS, TITLE	9/6/17	D.FRISIELLO

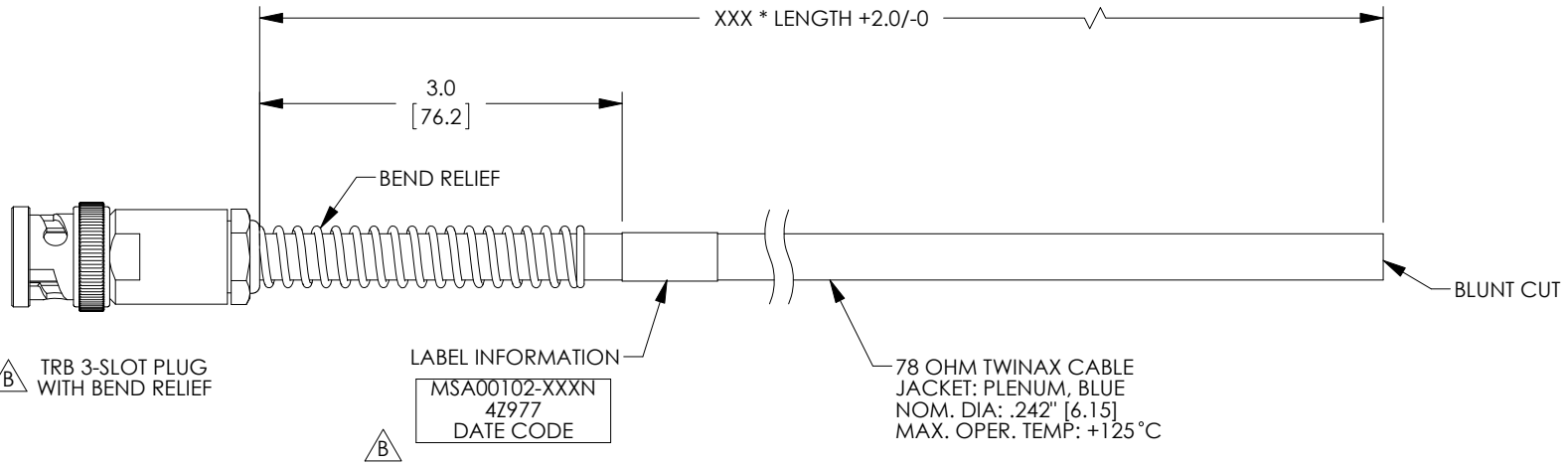

⚠ B TRB 3-SLOT PLUG WITH BEND RELIEF

⚠ B LABEL INFORMATION
MSA00102-XXXN
4Z977
DATE CODE

78 OHM TWINAX CABLE
JACKET: PLENUM, BLUE
NOM. DIA: .242" [6.15]
MAX. OPER. TEMP: +125°C

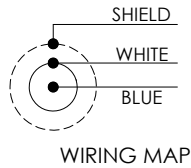

LENGTH CODE CHART		
CABLE # & LENGTH	LENGTH SYMBOL	EXAMPLES OF PART # USED
MSA00102-XXXN	WHERE XXX = LENGTH IN INCHES	MSA00102-12N (12.0 INCHES)

NON CONTROLLED DRAWING IF PRINTED



NOTES:

- *XXX = LENGTH IN INCHES
- CABLE ASSEMBLY SHALL BE TESTED FOR CONTINUITY.

AS9100C CERTIFIED			CAD SYSTEM DRAWING - DO NOT REVISE MANUALLY			
			SIGNATURE	DATE		MILESTEK CORPORATION 1506 INTERSTATE 35 WEST DENTON, TX 76207 PHONE: 866.524.1553 FAX: 940.591.7086
			DRAWN BY: J.YOU	06/30/17		
			CHECKED BY: M.HEARN	06/30/17	TITLE CA PLN TWNX PBR-BLNT	SIZE A
			APPROVED ENGINEERING: M.HEARN	06/30/17		
			APPROVED MANUFACTURING:		DRAWING NUMBER: MSA00102-XXXN	SCALE: NTS SHEET 1 OF 1
			CUSTOMER APPROVAL			
DASH	NEXT ASSY	USED ON	CUSTOMER REFERENCE DOCUMENT:		CAGE CODE: 4Z977	
APPLICATION						

UNLESS OTHERWISE SPECIFIED ALL DIMENSIONS ARE IN INCHES
 OVERALL CABLE LENGTH TOLERANCE:
 ≤12 [305] = +1 [25] / -0
 >12 [305] ≤60 [1524] = +2 [51] / -0
 >60 [1524] ≤120 [3048] = +4 [102] / -0
 >120 [3048] ≤300 [7620] = +6 [152] / -0
 >300 [7620] = +5% / -0%
 ALL OTHER DIMENSIONAL TOLERANCES:
 .X = ±.2 [5.08]
 .XX = ±.02 [5.1]
 .XXX = ±.005 [1.3]

MilesTek

TITLE
CA PLN TWNX PBR-BLNT

DRAWING NUMBER:
MSA00102-XXXN

CAGE CODE: 4Z977

SCALE: NTS SHEET 1 OF 1