

REVISION			
REV	DESCRIPTION	DATE	APPROVED
A	OUT LINE DRAWING	08/15/14	

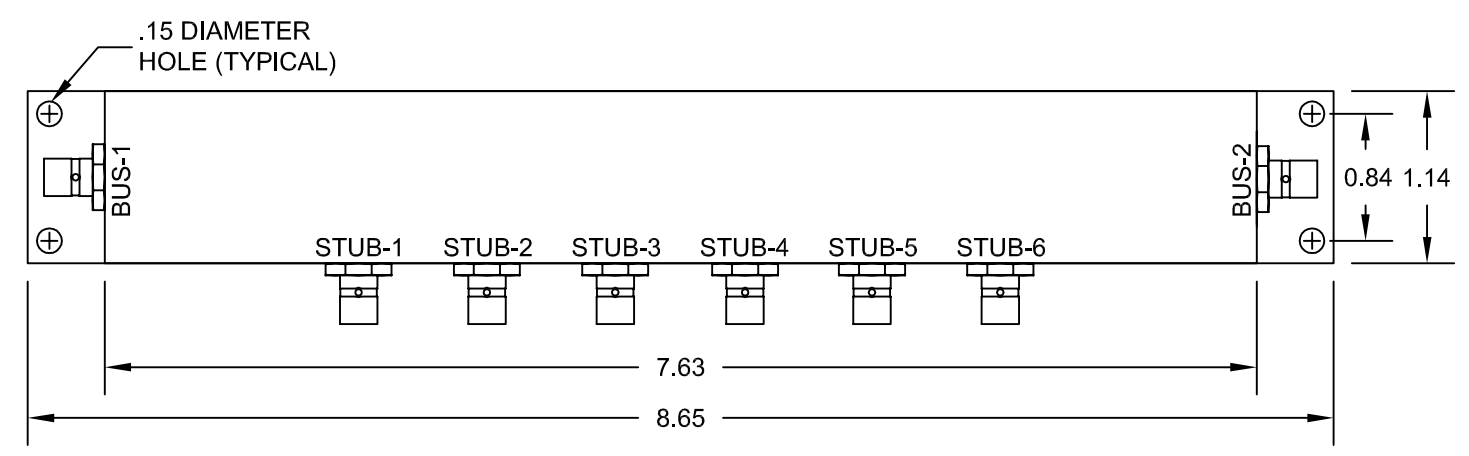
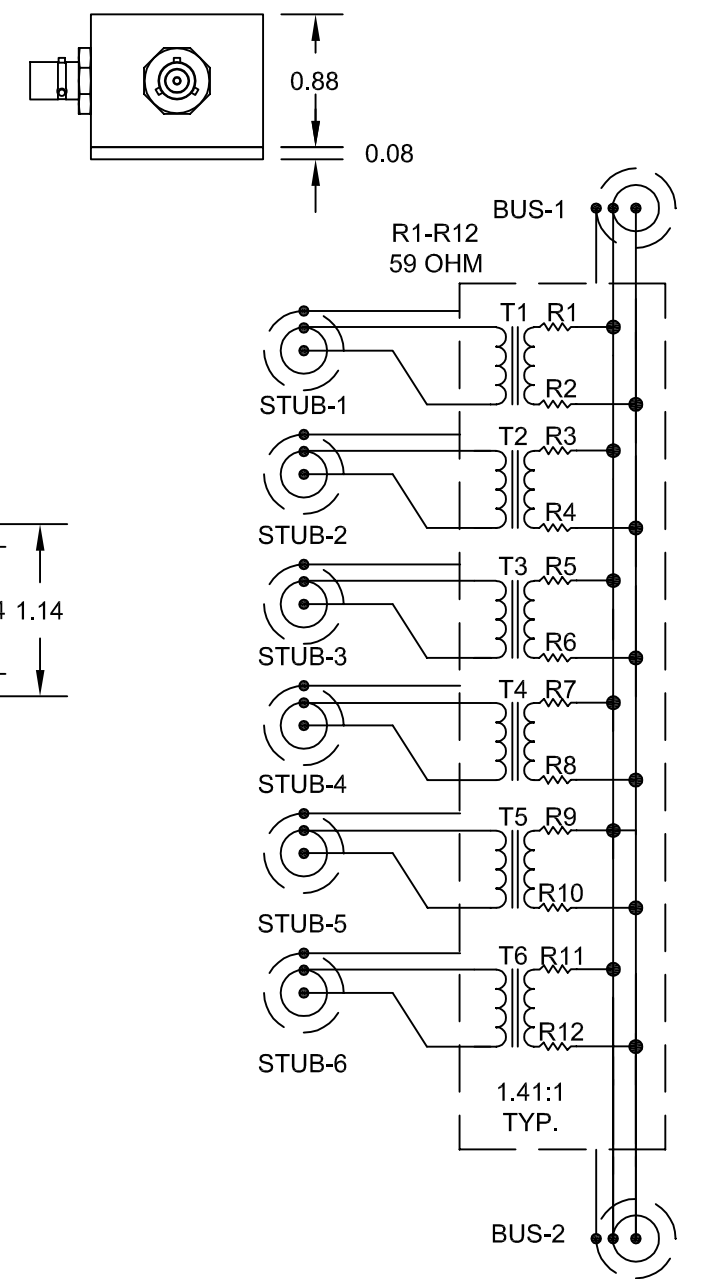
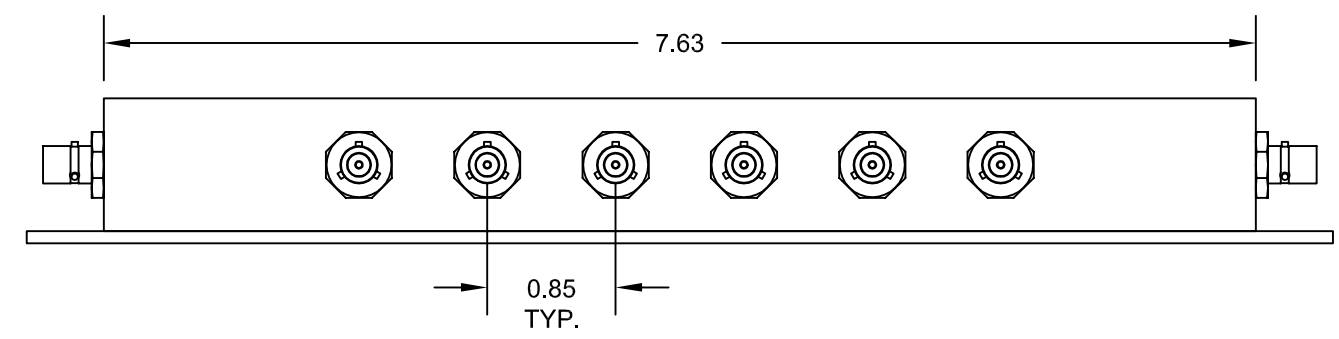

COUPLER SPECIFICATIONS:

T1 = 1.4CT:1CT
R1-R12 = 59.0 OHM
CONNECTORS: 3 LUG SUB MIN JACK
HOUSING: DIE CAST A360 ALUMINUM ALLOY
CLEAR ALODINE AND PAINTED WITH BAKED ENAMEL, COLOR BLUE.
BASE PLATE: 5052-H32 ALUMINUM, SATIN FINISH
ENCAPSULANT COMPOUND: PC2021AB-400CC

PROPRIETARY NOTICE

This document discloses confidential subject matter in which MilesTek Corporation and its subsidiaries have proprietary rights. Neither receipt nor possession thereof confers or transfers any right to reproduce or disclose the document, any part thereof, any information contained therein, or any physical article or device, or to practice any method or process, except by written permission from, or written agreement with MilesTek Corporation and its subsidiaries.

AS9100C CERTIFIED		CAD SYSTEM DRAWING - DO NOT REVISE MANUALLY			
UNLESS OTHERWISE SPECIFIED ALL DIMENSIONS ARE IN INCHES		SIGNATURE	DATE	MILESTEK CORPORATION 1506 INTERSTATE 35 WEST DENTON, TX 76207 PHONE: 866.524.1553 FAX: 940.591.7086	
DECIMALS--X-- ± N/A		DRAWN BY: D. JOHNSON	08/15/14		
DECIMALS--XX-- ±1,00		CHECKED BY: M. GREENHILL	08/15/14	TITLE 6 STUB BUS COUPLER ASSEMBLY	
DECIMALS--XXX-- ±N/A		APPROVED ENGINEERING:			
ANGLES-- ±1N/A		APPROVED MANUFACTURING:		SIZE D DRAWING NUMBER: BC-1003-6	
CUSTOMER CONTACT:		CUSTOMER APPROVAL			
DASH	NEXT ASSY	USED ON	CUSTOMER REFERENCE DOCUMENT:	SCALE: NTS DO NOT SCALE DRAWING SHEET 1 OF 1	
APPLICATION			CAGE CODE: 4Z977		