

.150" DIAMETER

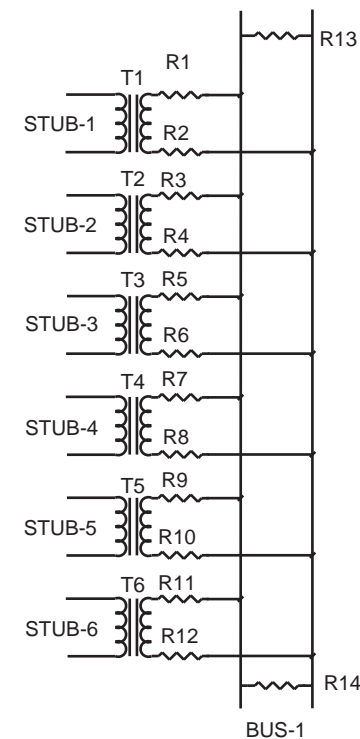
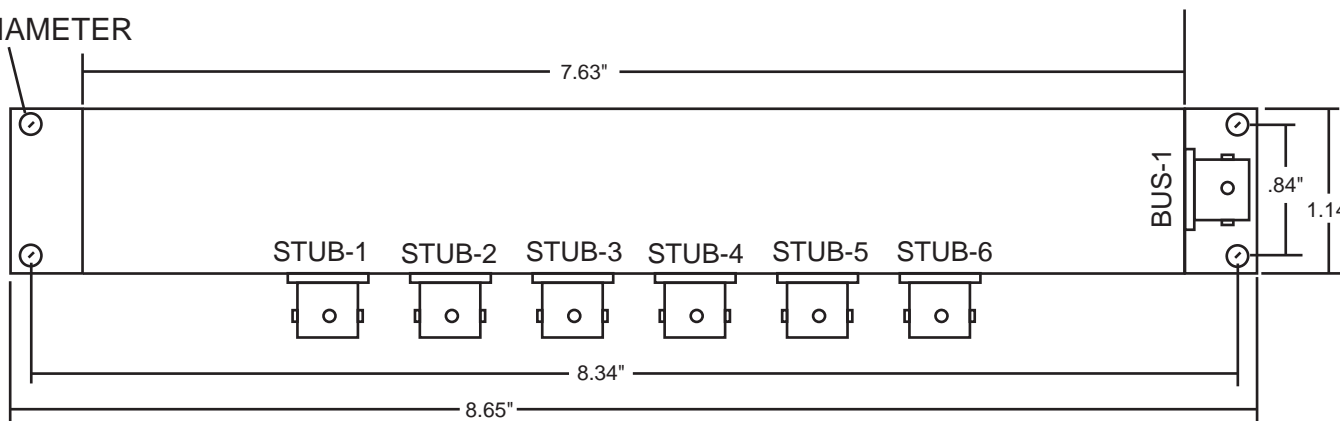

HOUSING: DIE CAST ALUMINUM, ALLOY A360  
 WITH BAKED BLUE ENAMEL FINISH PER  
 FED-STD-595, COLOR 25109.  
 COVER: ALUMINUM ALLOY 1100-H14 WITH  
 CLEAR ALODINE PER MIL-A-8625.  
 SHAPE: 1 DEGREE DRAFT PER SIDE.

90-52216	1.41:1	59 ohm, 2W, 1	—	78.7 ohm, 2W, 1	3-LUG TRB MILESTEK 10-06593 OR EQUIV	3-LUG TRB PLUG MILESTEK 10-06030-XXX OR EQUIV	 1506 I-35 W DENTON TX 76207 USA 1-800-958-5173 940-484-9400 www.milestek.com militarysales@milestek.com	DRAWN BY: CHRIS RIEMER	DATE:	
90-52546	1:1	59 ohm, 2W, 1	—	78.7 ohm, 2W, 1				APPROVED BY: MARK HEARN	9/11/2012	
90-52646	1:1	54.9 ohm, 2W, 1	—	78.7 ohm, 2W, 1				TITLE: 6 STUB BUS COUPLER - BUS JACK RIGHT		
								CAGE CODE: 4Z977	DWG NO:	REV: 1
								SCALE: NOT TO SCALE	SHEET: 1 OF 1	
MILESTEK PART NO	XFMR RATIO T1-T6	RESISTOR VALUE R1-R12	RESISTOR VALUE R13	RESISTOR VALUE R14				BUS & STUB CONNECTOR	MATING CONNECTOR	