

REVISION			
REV	DESCRIPTION	DATE	APPROVED
A	OUT LINE DRAWING	04/23/13	

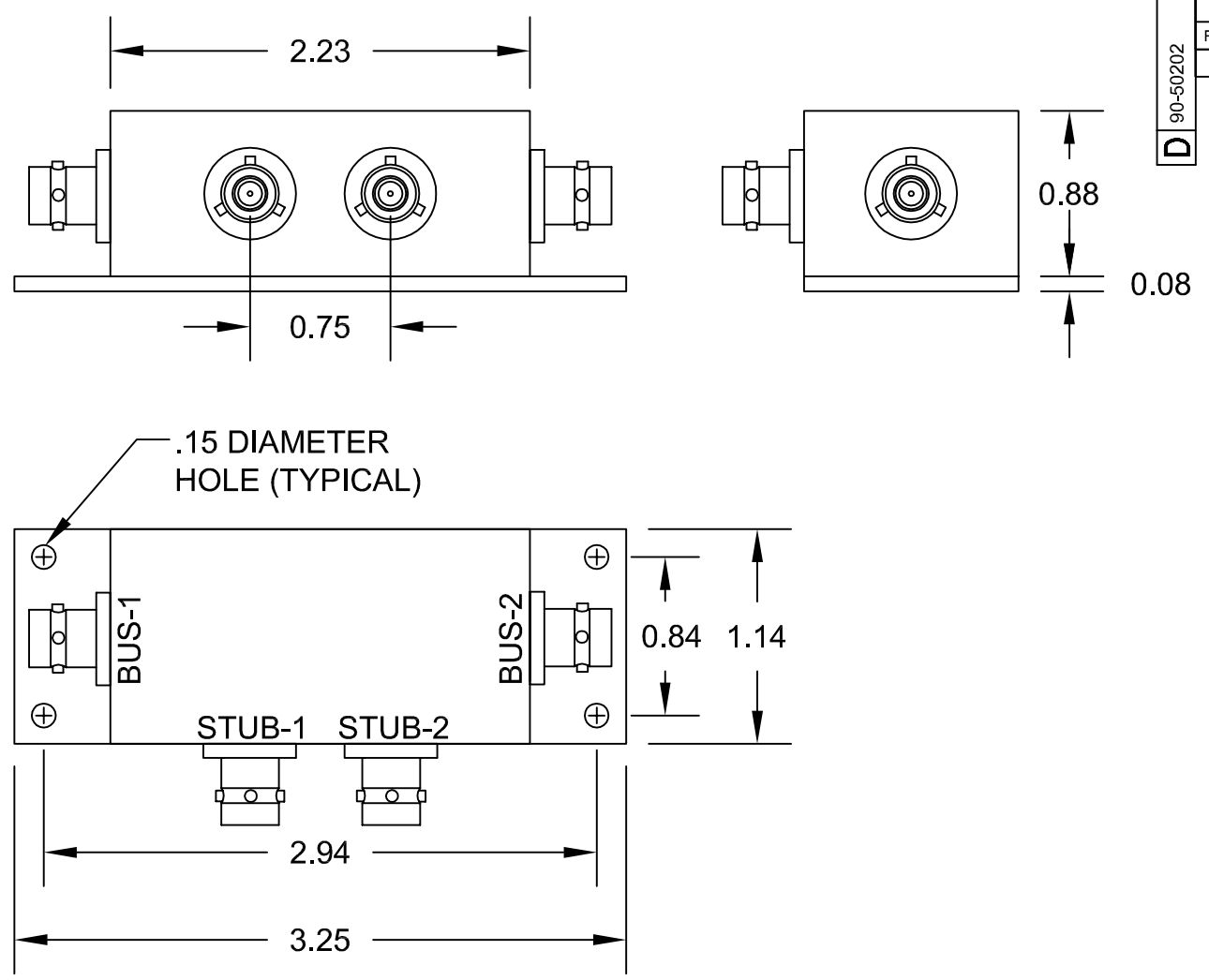
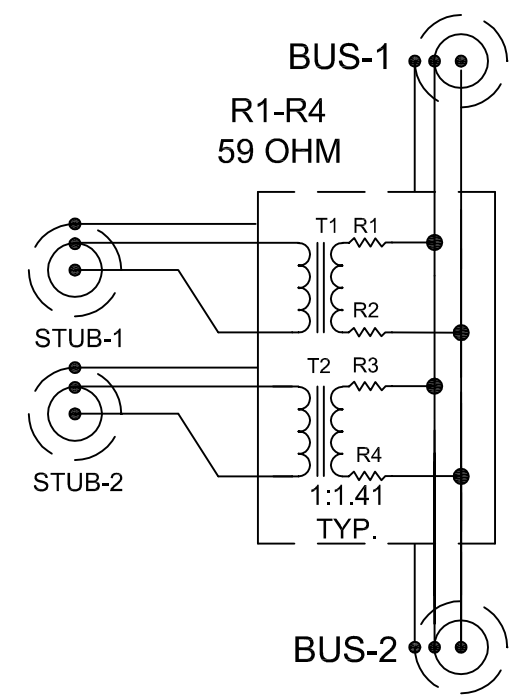

1.0 ELECTRICAL SPECIFICATIONS: IAW MIL-STD-1553B

- | | |
|---------------------------|--|
| 1.1 DROOP | 20% MAXIMUM |
| 1.2 OVERSHOOT AND RINGING | +/- 1.0V PK-PK |
| 1.3 TRANSFORMER RATIO | (T1-T2) 1.41CT:1CT |
| 1.4 FAULT PROTECTION | (R1-R4) 59 ohm +/- 1%, 2WATT PER MIL-R-39007 |
| 1.5 COMMON MODE REJECTION | -55 dB @ 1 MHz |
| 1.6 NOMINAL UNIT WEIGHT | 2.50 OUNCES (70.87 GRAMS) |

2.0 MECHANICAL SPECIFICATIONS:

- 2.1 HOUSING: DIE CAST A360 ALUMINUM ALLOY. CLEAR ANODIZED AND PAINTED WITH TEXTURE. BAKED ENAMEL, COLOR BLUE.
- 2.2 BASE PLATE: 5052-H32 ALUMINUM, SATIN FINISH.
- 2.3 CONNECTOR 10-06569 OR EQUIVALENT

3.0 ENVIRONMENTAL:

- 3.1 OPERATING AND STORAGE TEMPERATURE -55 C TO + 125 C

4.0 ASSEMBLY:

- 4.1 ASSEMBLED PER IPC J-STD-001E

PROPRIETARY NOTICE

This document discloses confidential subject matter in which MilesTek Corporation and its subsidiaries have proprietary rights. Neither receipt nor possession thereof confers or transfers any right to reproduce or disclose the document, any part thereof, any information contained therein, or any physical article or device, or to practice any method or process, except by written permission from, or written agreement with MilesTek Corporation and its subsidiaries.

AS9100C CERTIFIED		CAD SYSTEM DRAWING - DO NOT REVISE MANUALLY				
UNLESS OTHERWISE SPECIFIED ALL DIMENSIONS ARE IN INCHES DECIMALS--X-- ± N/A DECIMALS--XX-- ±1.00 DECIMALS--XXX-- ±N/A ANGLES-- ±1N/A		SIGNATURE	DATE	MilesTek	MILESTEK CORPORATION 1506 INTERSTATE 35 WEST DENTON, TX 76207 PHONE: 866.524.1553 FAX: 940.591.7086	
		DRAWN BY: D. JOHNSON	04/23/13			
		CHECKED BY: M. GREENHILL	04/23/13	TITLE 2 STUB NON TERMINATED BUS COUPLER ASSEMBLY		
		APPROVED ENGINEERING:		SIZE D	DRAWING NUMBER: 90-50202	SCALE: NTS
CUSTOMER CONTACT:		CUSTOMER APPROVAL:		CAGE CODE: 4Z977		
CUSTOMER REFERENCE DOCUMENT:		APPLICATION				