

7/16-28UNEF-2B

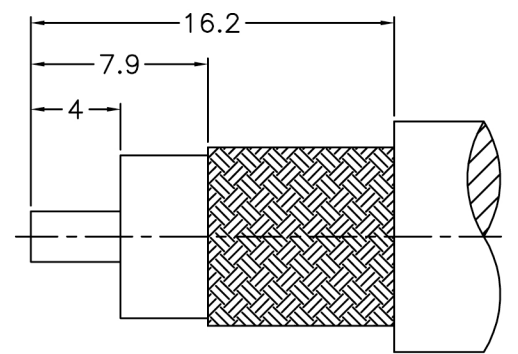

RECOMMENDED
CABLE STRIPPING DIM'S

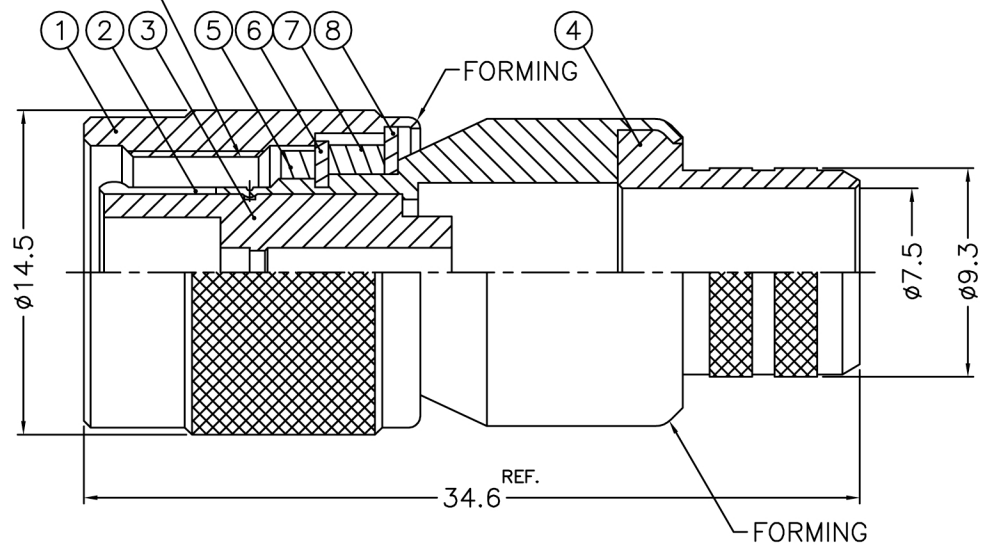
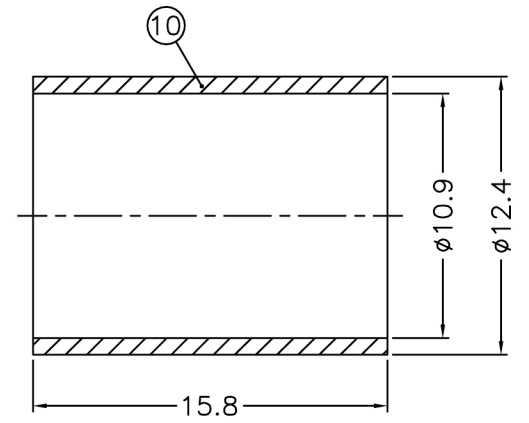
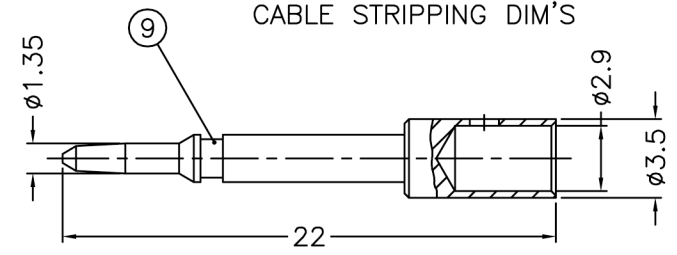

NOTES: FINISH (PLATING THICKNESS IN MICRO-INCHES)

1. BRASS
2. NICKEL PL. 100 MIN. THICK OVER COPPER PL. 50 MIN. THICK
3. GOLD PL. 3 MIN. THICK OVER NICKEL PL. 50 MIN. THICK OVER COPPER PL. 50 MIN. THICK
4. TEFLON

1. CRIMPED FERRULE
HEX. CRIMP SIZE .429"
2. CRIMPED CONTACT PIN
HEX. CRIMP SIZE .118"

8				DIMENSIONS ARE IN MILLIMETERS UNLESS OTHERWISE SPECIFIED TOLERANCES 0.5-6 = ±0.2 6-30 = ±0.4 30-120 = ±0.6 120-315 = ±1 315-1000 = ±1.6 1000-2000 = ±2.4	SIGNATURE	DATE	MilesTek MILESTEK CORPORATION 1506 INTERSTATE 35 WEST DENTON, TX 76207 PHONE: 866.524.1553 FAX: 940.591.7086
7					DRAWN BY: M. GREENHILL	10/01/2010	
6					CHECKED BY:		SIZE D
5					APPROVED ENGINEERING:		
4					APPROVED MANUFACTURING:		REV.-A
3	INSULATOR	TEFLON	NATURAL		DRAWING NUMBER:	CAGE CODE: 4Z977	DO NOT SCALE DRAWING
2	CONTACT PIN	BRASS	GOLD		11-TNC003.PDF		SHEET 1 OF 1
1	BODY	BRASS	NICKEL				
	DESCRIPTION	MATERIAL	FINISH				