

PROPRIETARY NOTICE

This document discloses confidential subject matter in which MilesTek Corporation and its subsidiaries have proprietary rights. Neither receipt nor possession thereof confers or transfers any right to reproduce or disclose the document, any part thereof, any information contained therein, or any physical article or device, or to practice any method or process, except by written permission from, or written agreement with MilesTek Corporation and its subsidiaries.

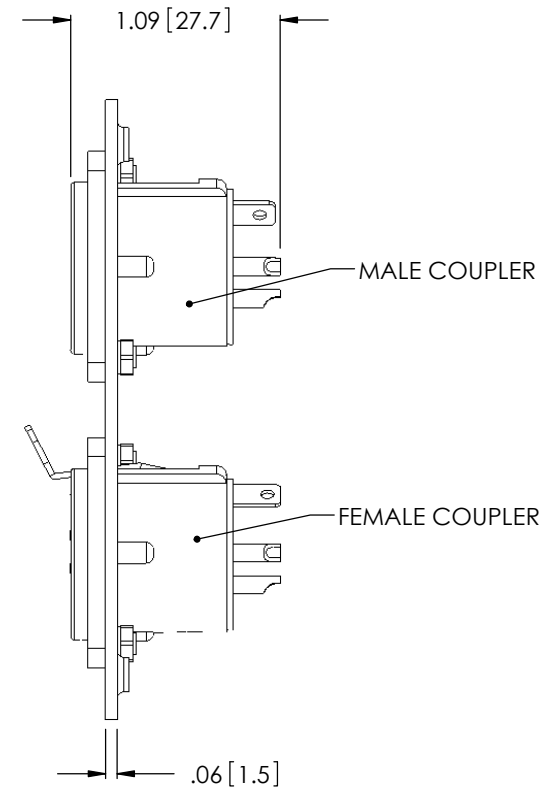
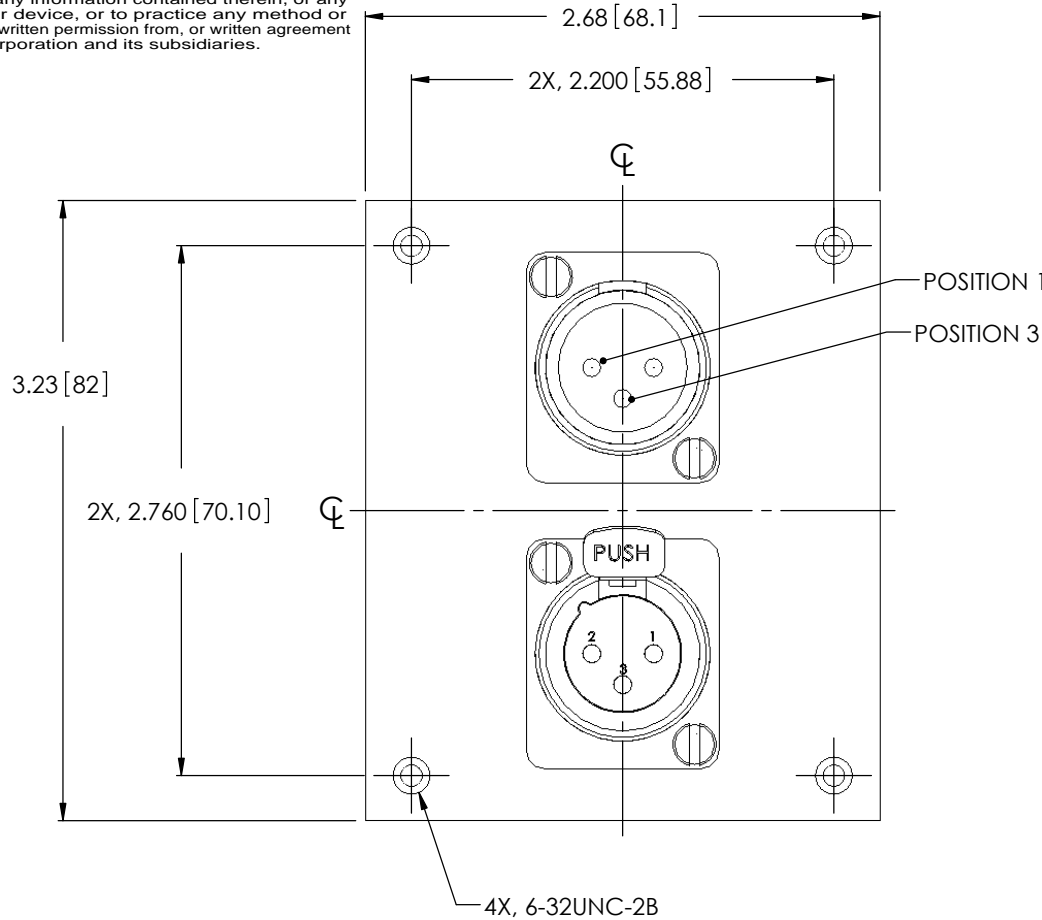

| REVISIONS | | | |
|-----------|-----------------|----------|------------|
| REV | DESCRIPTION | DATE | APPROVED |
| A | INITIAL RELEASE | 05/24/17 | B.PUCHASKI |
| | | | |
| | | | |

NOTES:

1. PANEL MATERIAL: .06 [1.5] THK COLD ROLLED STEEL.
2. PANEL FINISH: FLAT BLACK POWDER COAT.
3. ALL DIMENSIONS ARE FOR REFERENCE ONLY.
4. KIT CONTAINS 4, #6-32 UNC SCREWS.
5. KIT INDIVIDUALLY PACKAGED IN ACCORDANCE WITH SPECIFICATION PS-0054.

REGULATORY COMPLIANCE:
CE2011/65/EU (RoHS DIRECTIVE)

NON CONTROLLED DRAWING IF PRINTED

| AS9100C CERTIFIED | | | CAD SYSTEM DRAWING - DO NOT REVISE MANUALLY | | | |
|---|--|--|---|----------|---|--|
| UNLESS OTHERWISE SPECIFIED ALL DIMENSIONS ARE IN INCHES | | | SIGNATURE | DATE | | |
| OVERALL CABLE LENGTH TOLERANCE: | | | DRAWN BY: | 05/24/17 | MILESTEK CORPORATION 1506 INTERSTATE 35 WEST DENTON, TX 76207 PHONE: 866.524.1553 FAX: 940.591.7086 | |
| ≤12 [305] = +1 [25] / -0 | | | CHECKED BY: | 05/24/17 | TITLE | |
| >12 [305] ≤60 [1524] = +2 [51] / -0 | | | APPROVED ENGINEERING: | 05/24/17 | XLR MALE / FEMALE SUB PANEL | |
| >60 [1524] ≤120 [3048] = +4 [102] / -0 | | | APPROVED MANUFACTURING: | | SIZE | |
| >120 [3048] ≤300 [7620] = +6 [152] / -0 | | | CUSTOMER APPROVAL | | DRAWING NUMBER: | |
| >300 [7620] = +5% / -0% | | | | | A REF00042 | |
| ALL OTHER DIMENSIONAL TOLERANCES: | | | CUSTOMER REFERENCE DOCUMENT: | | SCALE: NTS | |
| .X = ±.2 [5.08] | | | APPLICATION | | SHEET 1 OF 1 | |
| .XX = ±.02 [1.51] | | | DASH NEXT ASSY USED ON | | | |
| .XXX = ±.005 [1.3] | | | CAGE CODE: 42977 | | | |