

REVISIONS	
ISS	DESCRIPTION\DATE
A1	增加刻字\04/01/13"

RoHS COMPLIANT

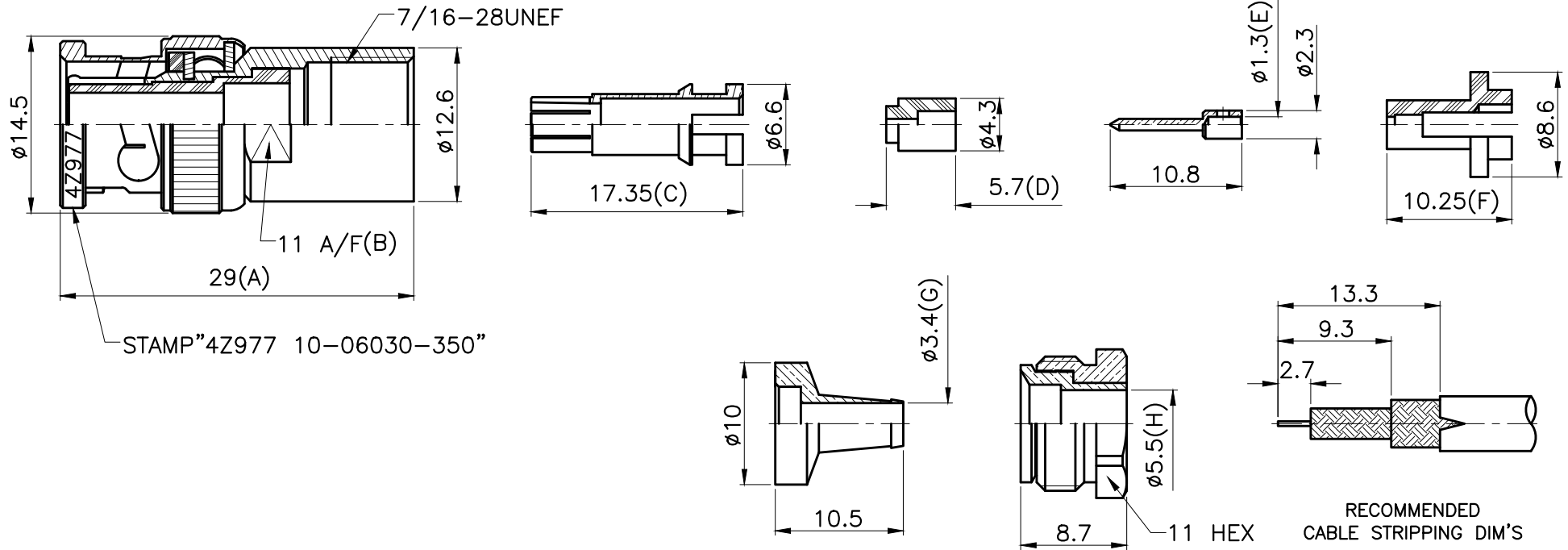

NOTES: FINISH (PLATING THICKNESS IN MICRO-INCHES)

1. BRASS PER QQ-B-626
2. NICKEL PL 70~200 THICK OVER COPPER PL 60~160 THICK
3. GOLD PL 3~10 THICK OVER NICKEL PL 70~200 THICK OVER COPPER PL 60~160 THICK
4. PHOSPHOR BRONZE PER QQ-B-750
5. GOLD PL 30~40 THICK OVER NICKEL PL 70~200 THICK OVER COPPER PL 60~160 THICK

MilesTek  MilesTek Corporation
 1506 Interstate 35 West
 Denton, Tx 76207
 Telephone: 940.484.9400 . Toll Free: 866.524.1553
 Fax: 940.591.7086 . Web: www.milestek1553.com

TITLE: TRB PLUG CLAMP (FOR TRC-75-1)

PA. NO: 10-06030-350 CAGE CODE: 4Z977

DRAWING NO: 67015-110-A1

APRD: MARK HEARN
 CHKD: ROBERT PEREZ
 DR:

UNLESS OTHERWISE SPECIFIED TOLERANCES
 0.5-6 = ±0.2
 >6-30 = ±0.4
 >30-120 = ±0.6
 >120-315 = ±1
 >315-1000 = ±1.6
 ANGLES = ±5°

DATE: 04/01/13"

SHEET: .

UNIT: mm

SCALE: 2/1

NUT	NOTE 1	NOTE 2
BRAID HOLDER	NOTE 1	NOTE 2
BRAID HOLDER	NOTE 1	NOTE 2
INSULATOR	PTFE	WHITE
CONTACT PIN	NOTE 1	NOTE 5
INSULATOR	PTFE	WHITE
BODY	NOTE 4	NOTE 3
SHELL	NOTE 1	NOTE 2
GASKET	SILICONE	RED
WASHER	SS41	NOTE 2
SPRING	SK5	NOTE 2
WASHER	SS41	NOTE 2
INSULATOR	PTFE	WHITE
BODY	NOTE 1	NOTE 2
NO.	DESCRIPTION	MATERIAL
		FINISH